

Projeção Ortográfica

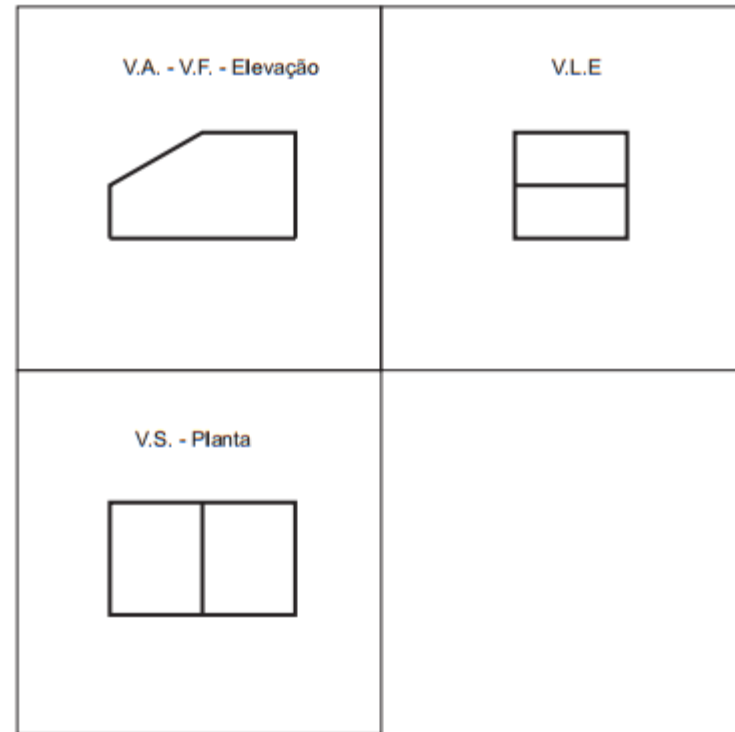

Aula 06
Desenho

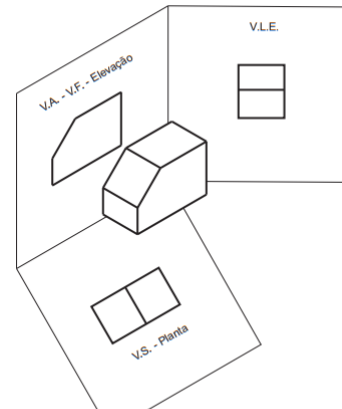
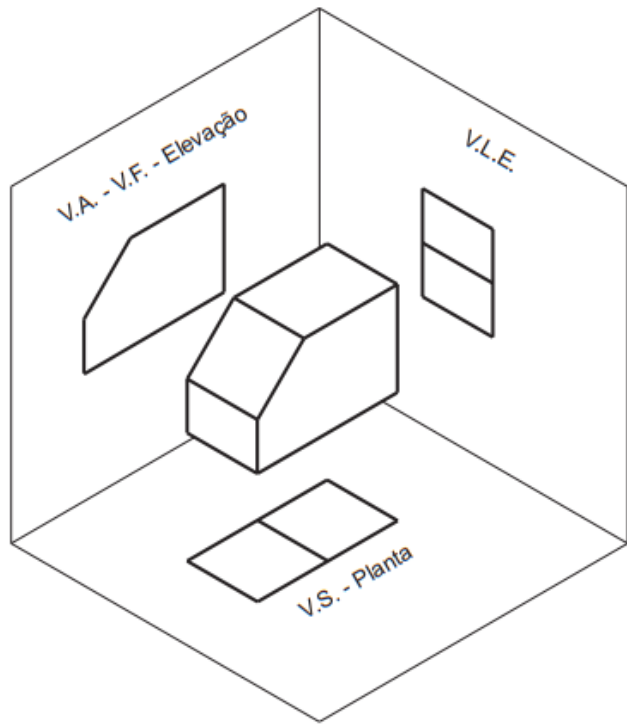

V.A = Vista Anterior

V.F = Vista Frontal

V.S = Vista Superior

V.L.E = Vista Lateral Esquerda



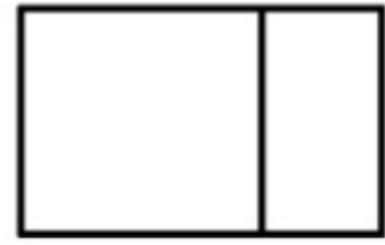
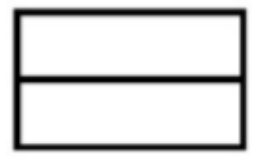
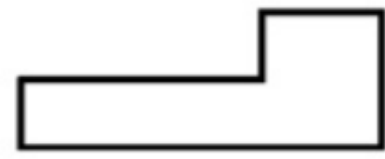
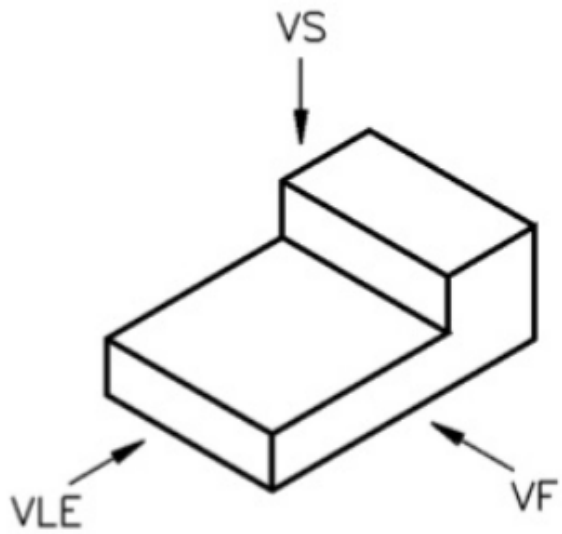

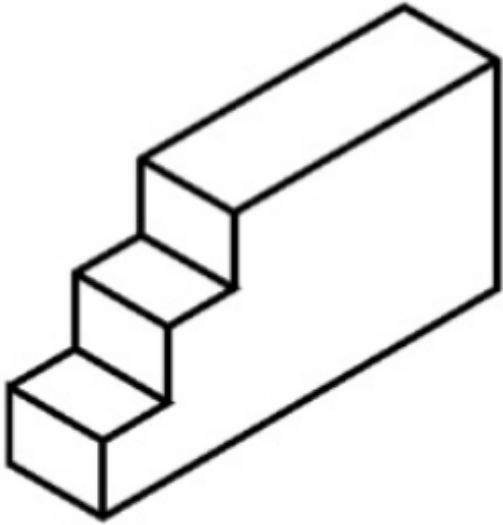

Linha tracejada

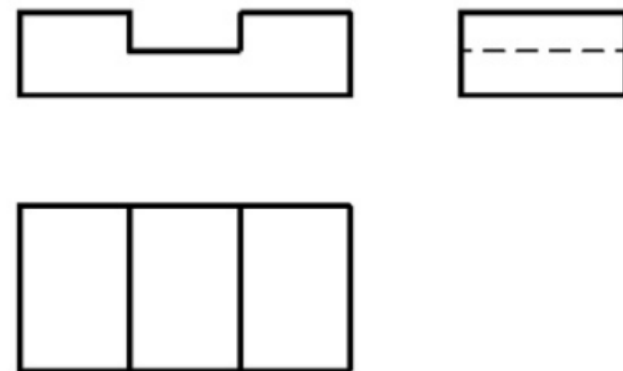
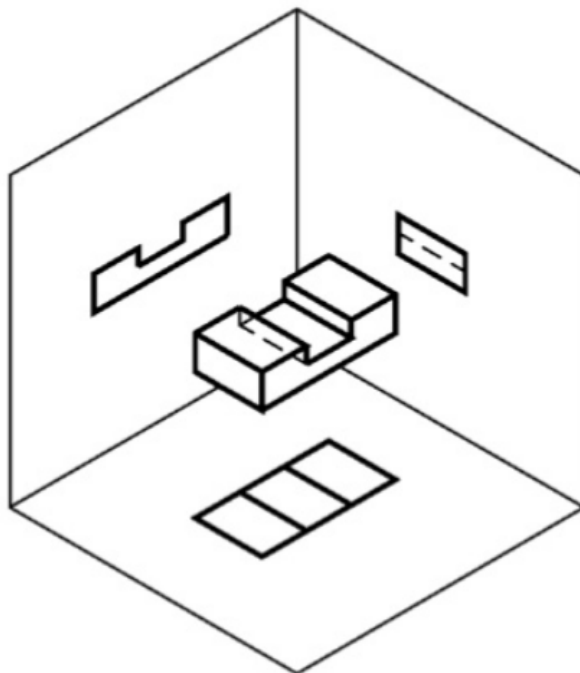
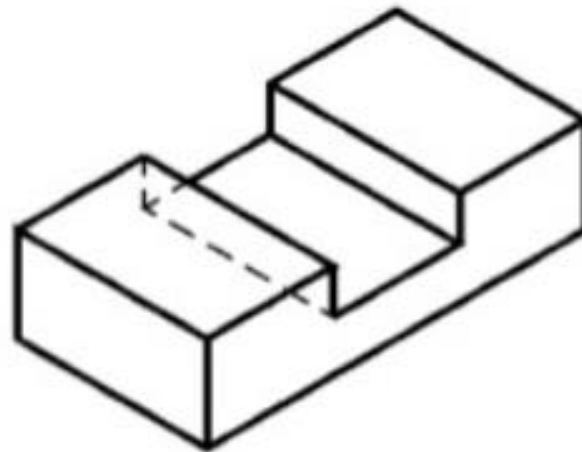

Linha tracejada estreita

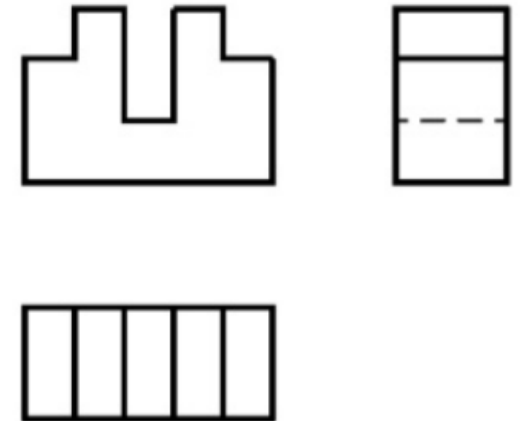
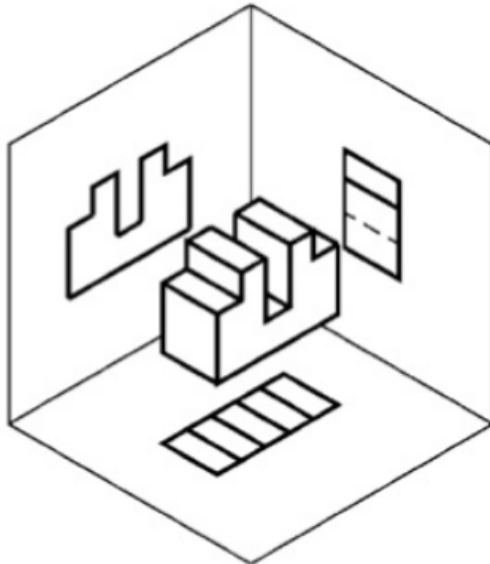
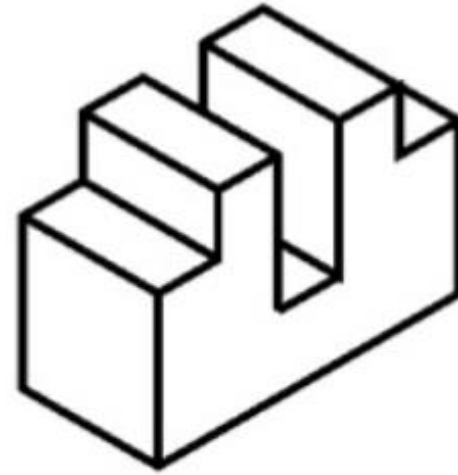

Elementos paralelos e oblíquos

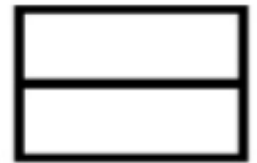
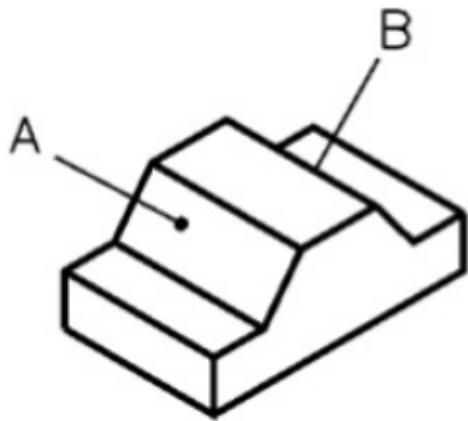

Elementos paralelos e oblíquos

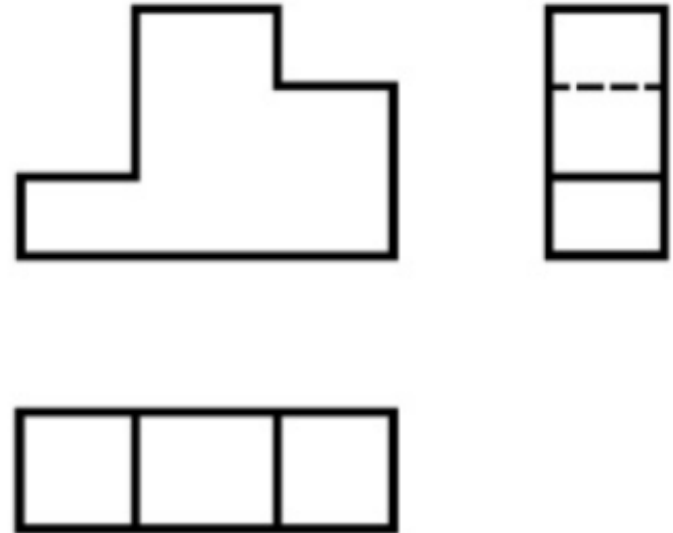
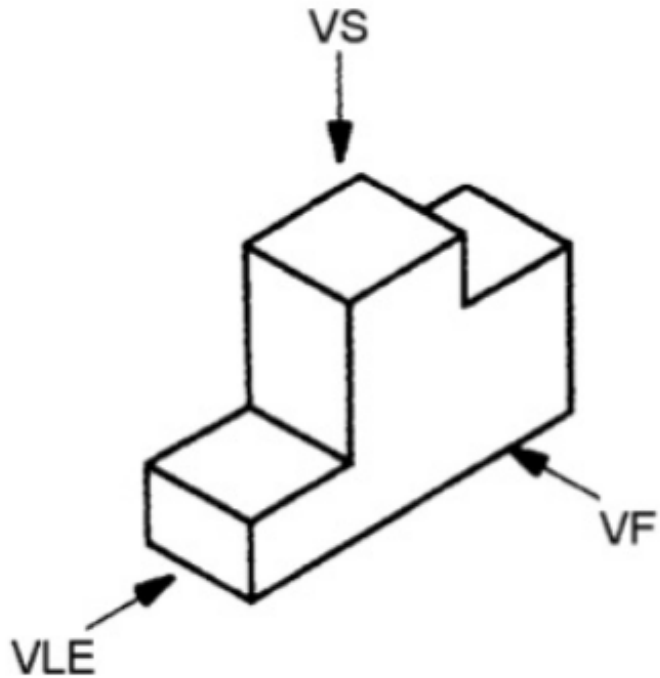

Elementos com superfícies inclinadas

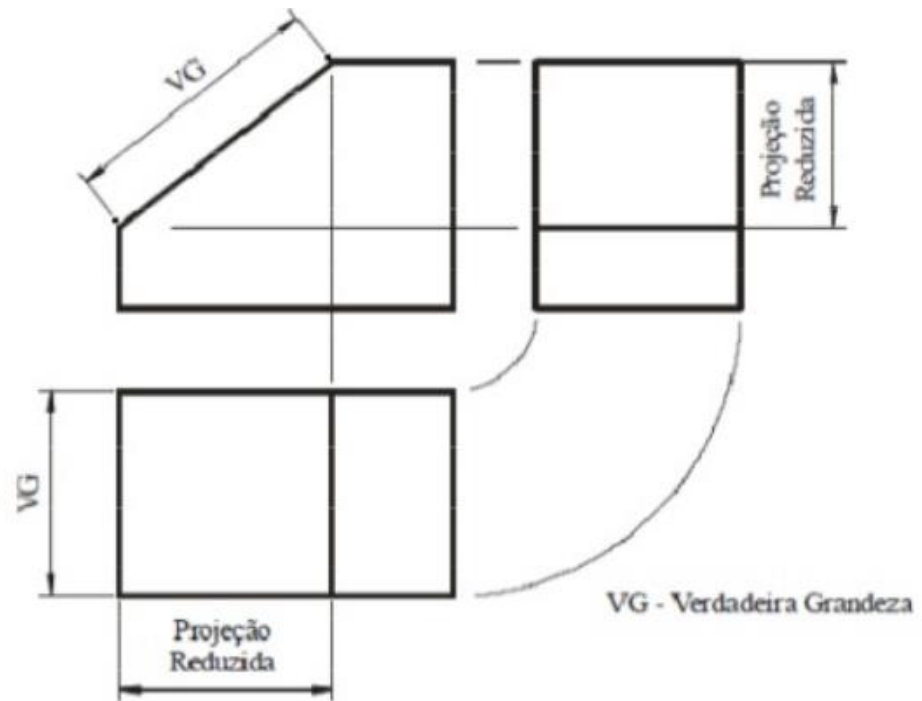
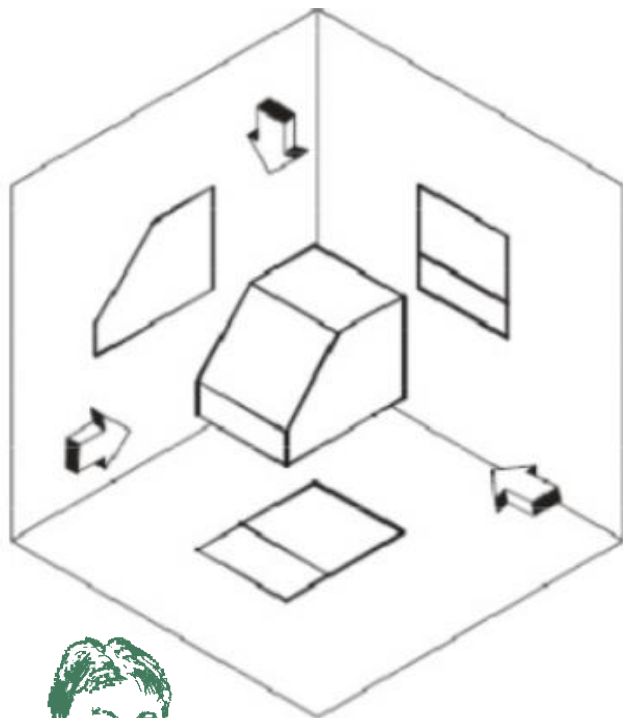

superfícies inclinadas nos três planos

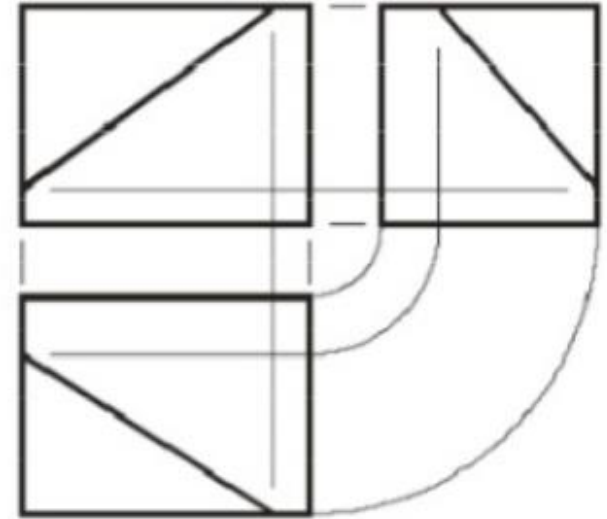
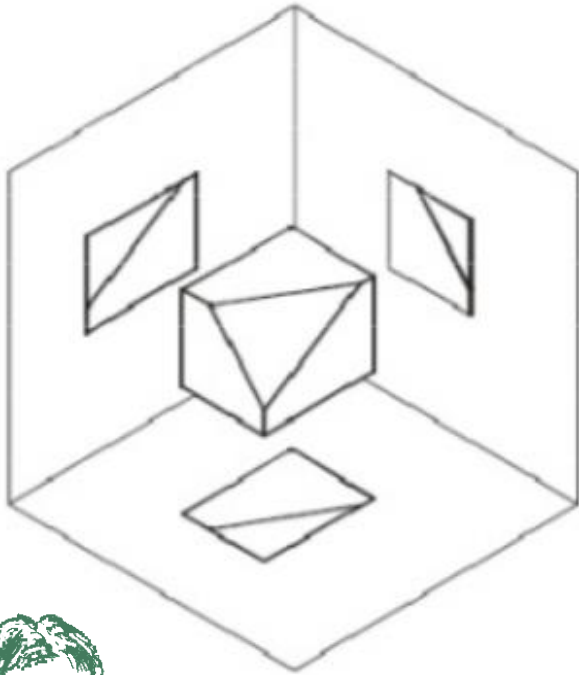

Elementos com superfícies curvas

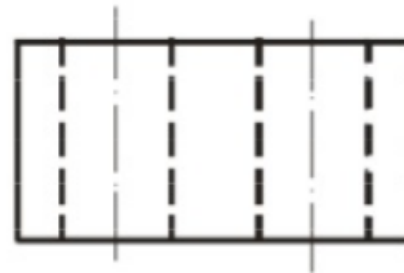
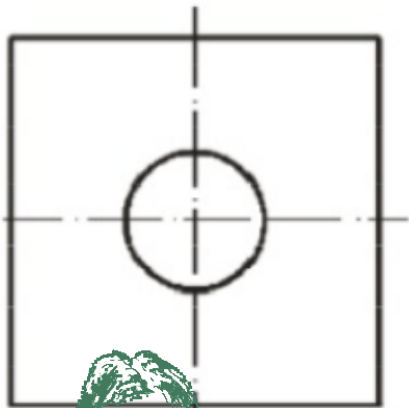
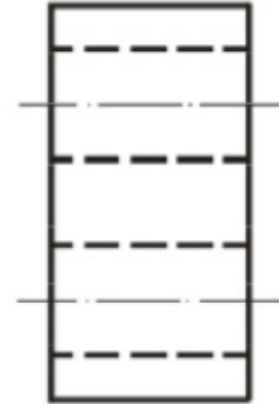
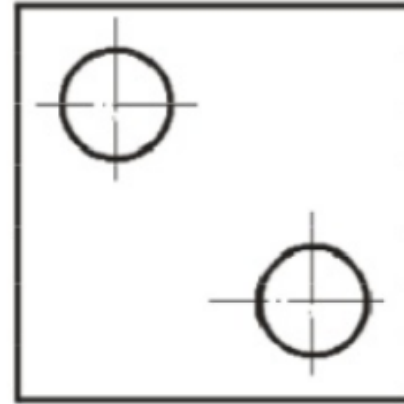
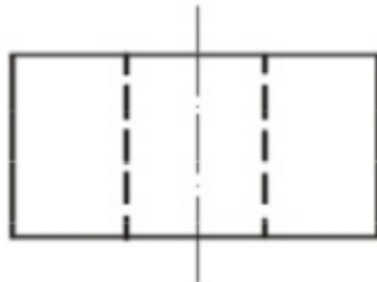
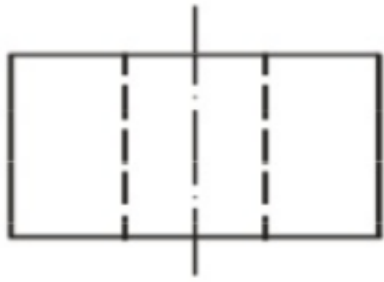

Elementos com arestas coincidentes

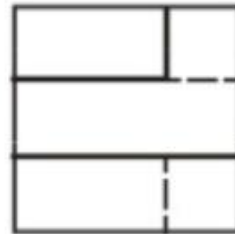
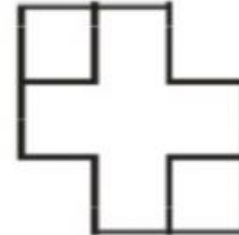
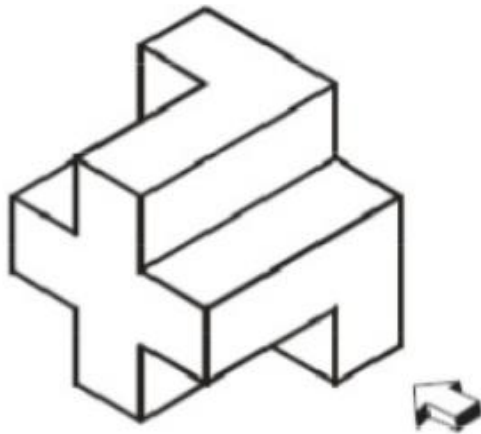

•A *linha cheia* prevalece sobre a *linha tracejada*.

•As linhas que representam arestas (*linha cheia ou linha tracejada*) prevalecem sobre as linhas auxiliares (*linha de centro*).



Escolha das vistas

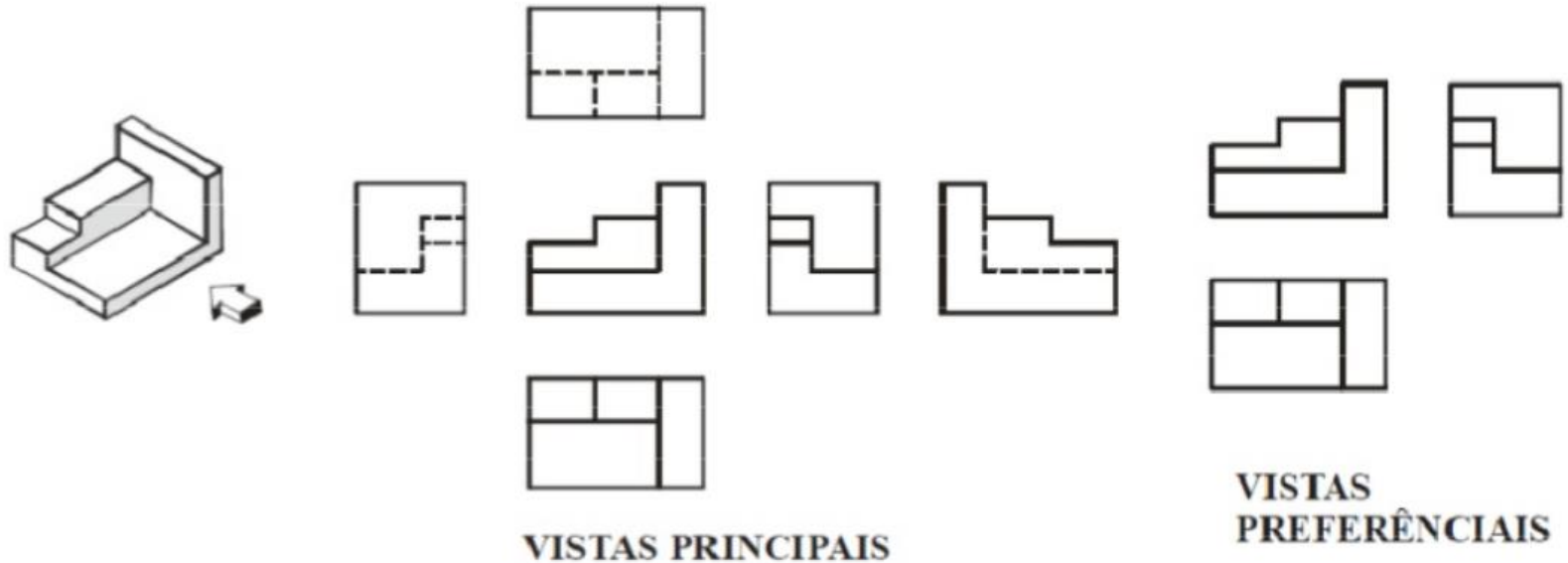

Considerando como frente a direção indicada, as três vistas preferenciais do 1º diedro são suficientes para representar o objeto.

As outras três vistas, além de apresentarem partes ocultas, são desnecessárias na definição da forma do objeto.

Escolha das vistas

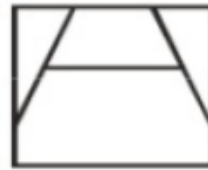
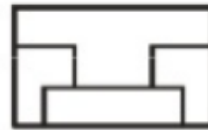
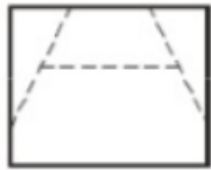

VISTAS PRINCIPAIS

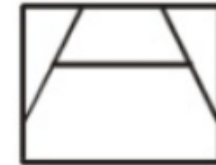
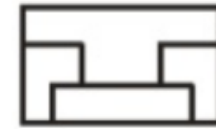

VISTAS PREFERÊNCIAS



1º Diedro

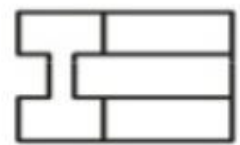
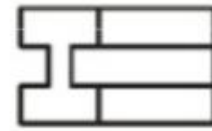
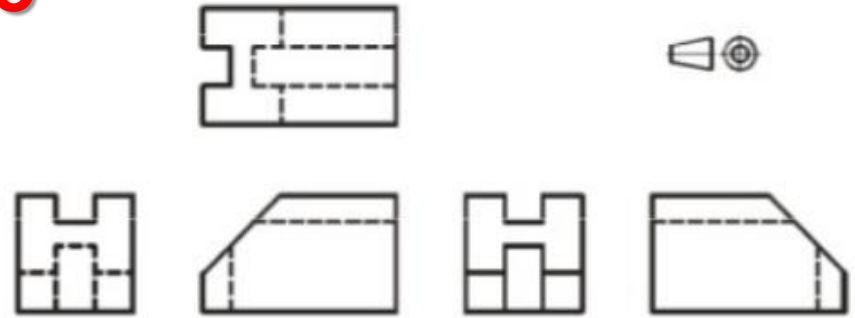
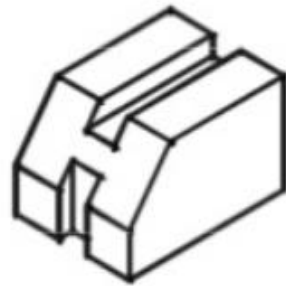

3º Diedro

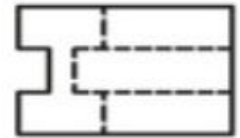
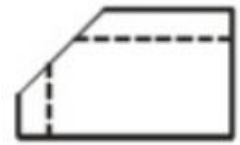

Desenho de perspectiva

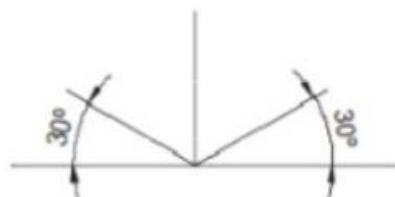
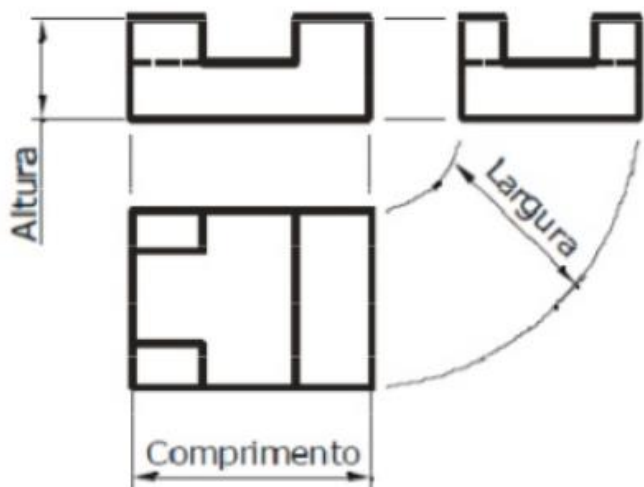

PASSO 1

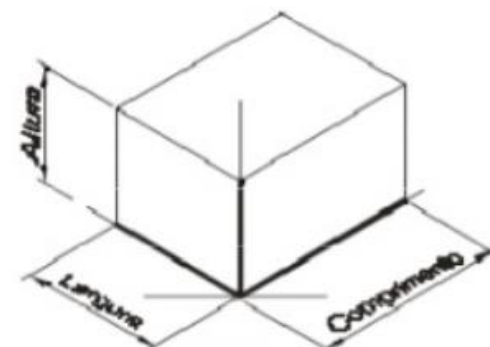

PASSO 2

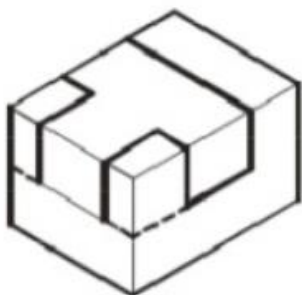

PASSO 3



PASSO 4



PASSO 5



Desenho de perspectiva com inclinações

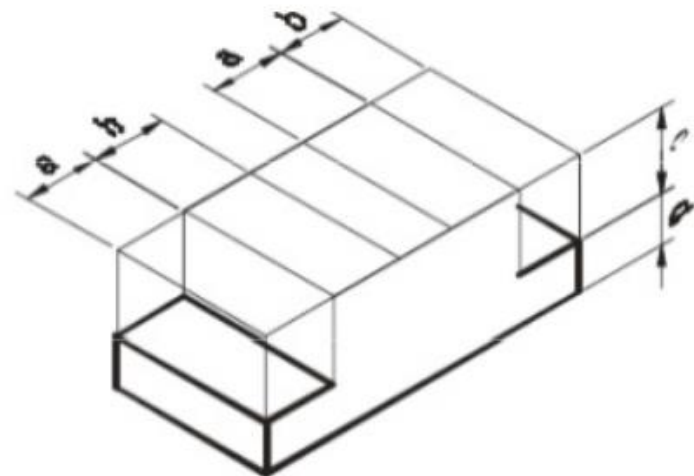
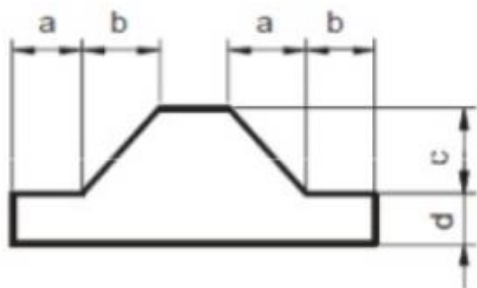

PASSO 1

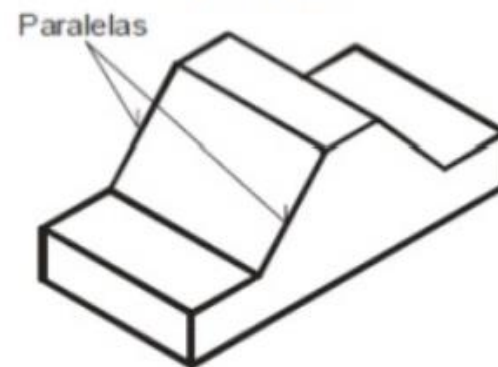

PASSO 3

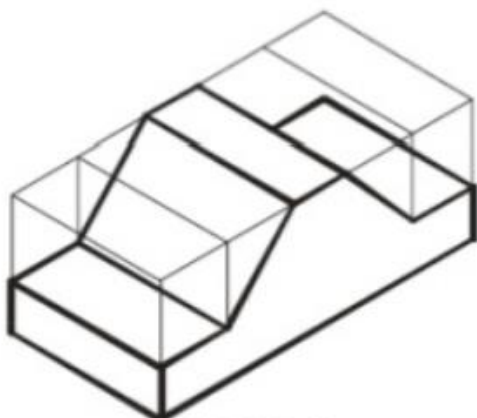

PASSO 2



Desenho de perspectiva com superfícies curvas

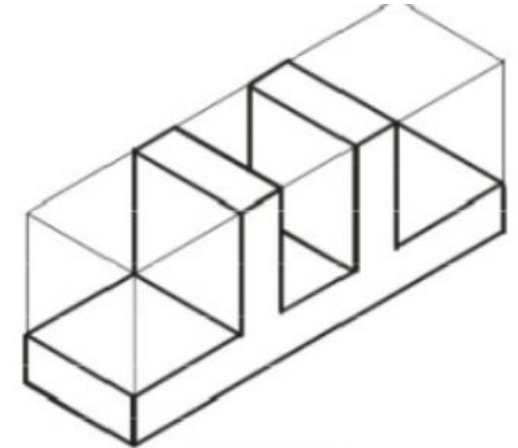
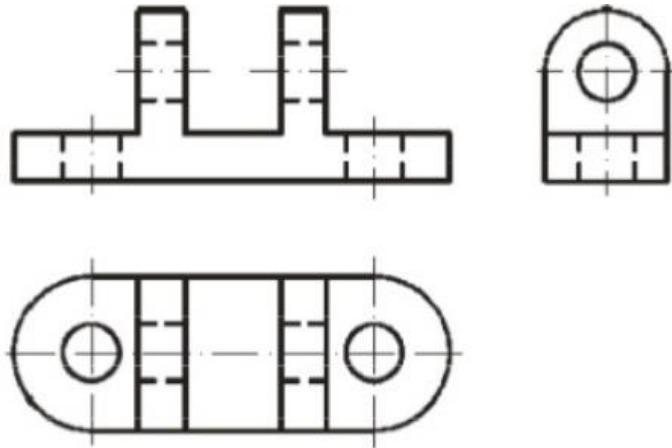

PASSO 1

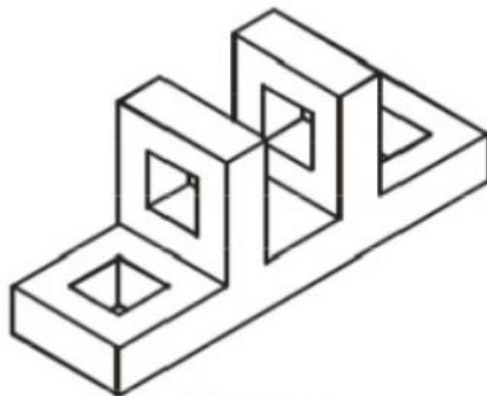

PASSO 2

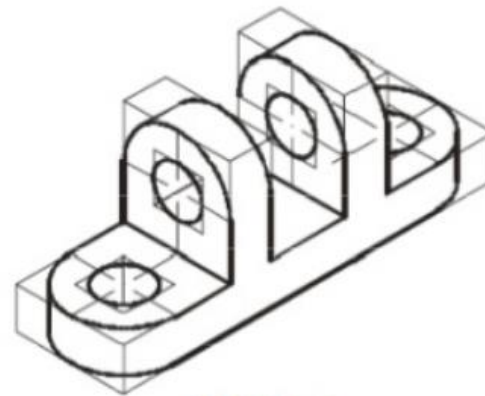

PASSO 3

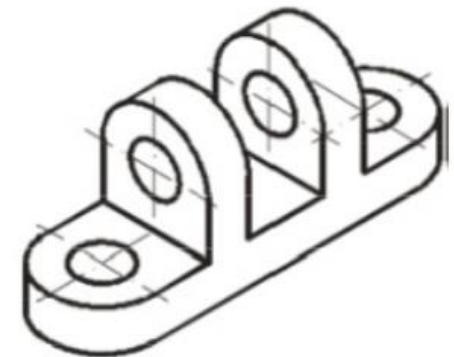

PASSO 4



Desenho em corte

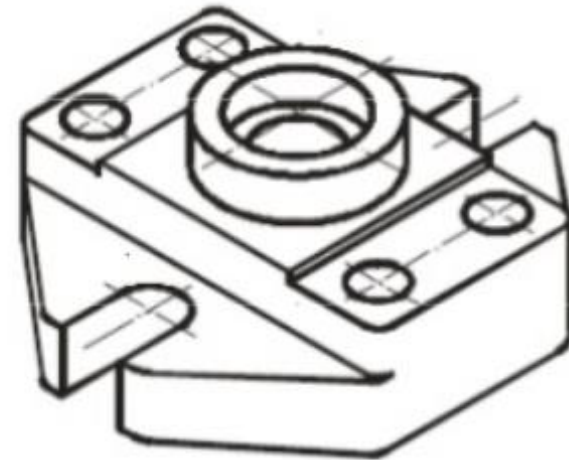
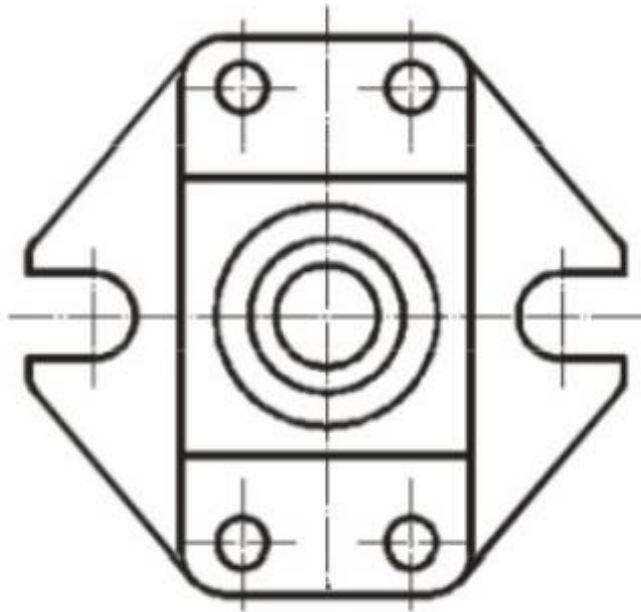
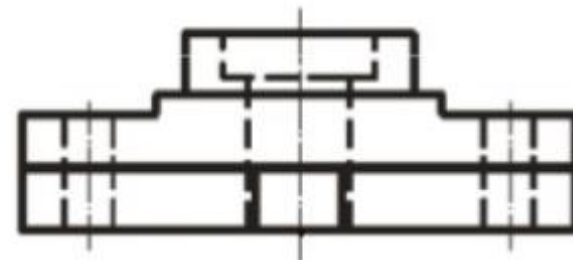
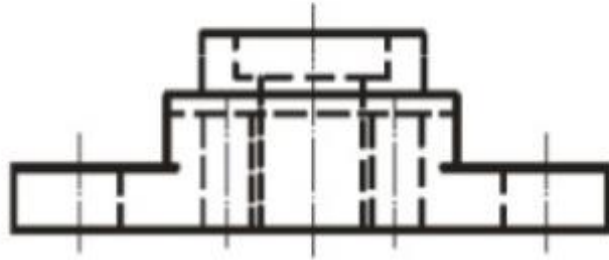

Desenho em meio corte

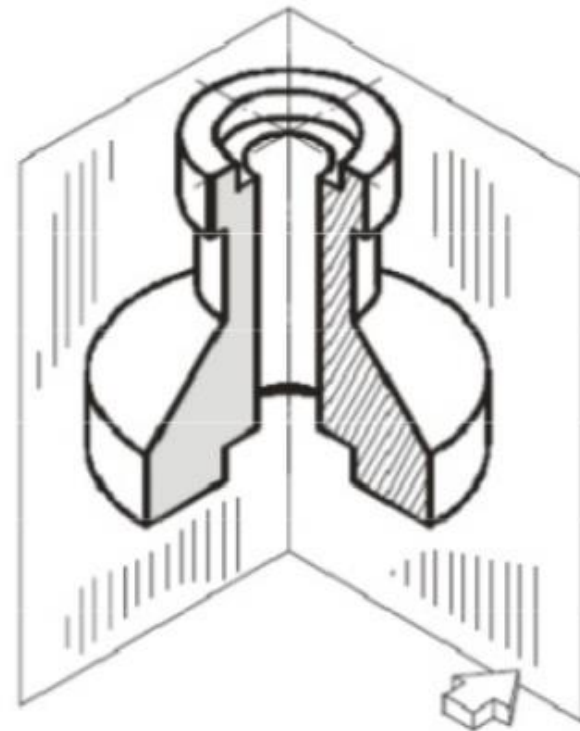
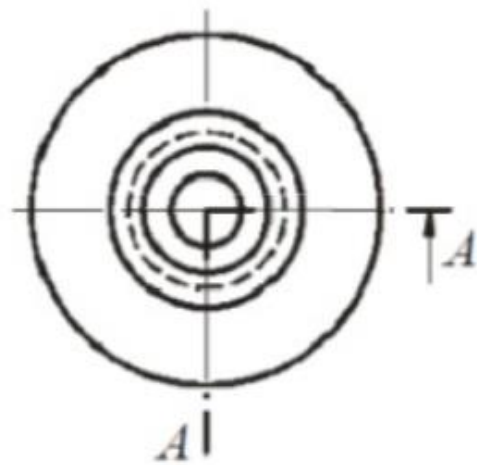
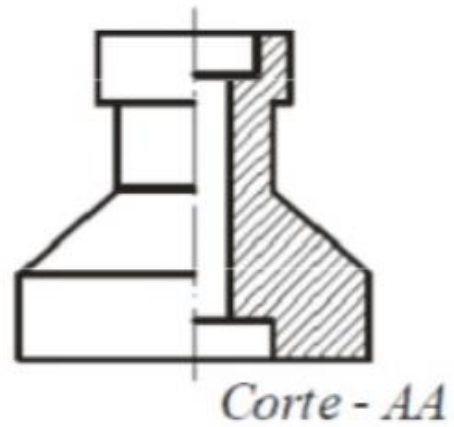

Elementos representados por uma única vista

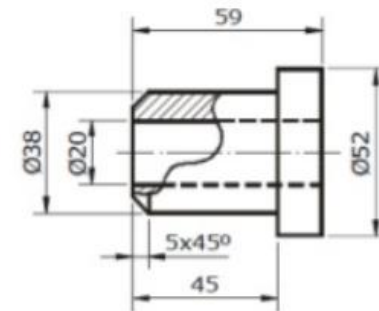
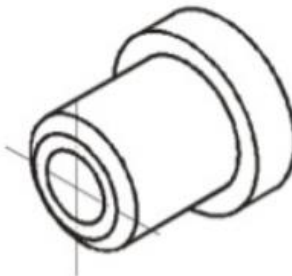
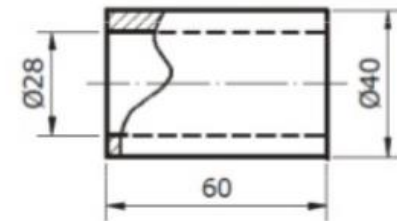
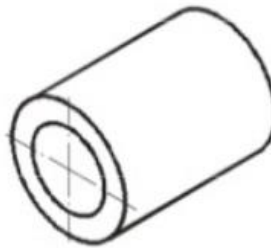
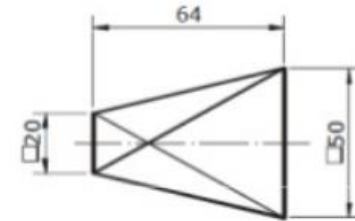
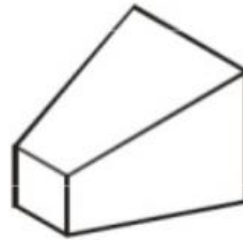

Elementos representados por uma única vista

