

Legislação



Aula 06

Projeto Arquitetônico

Legislação - habitação unifamiliar

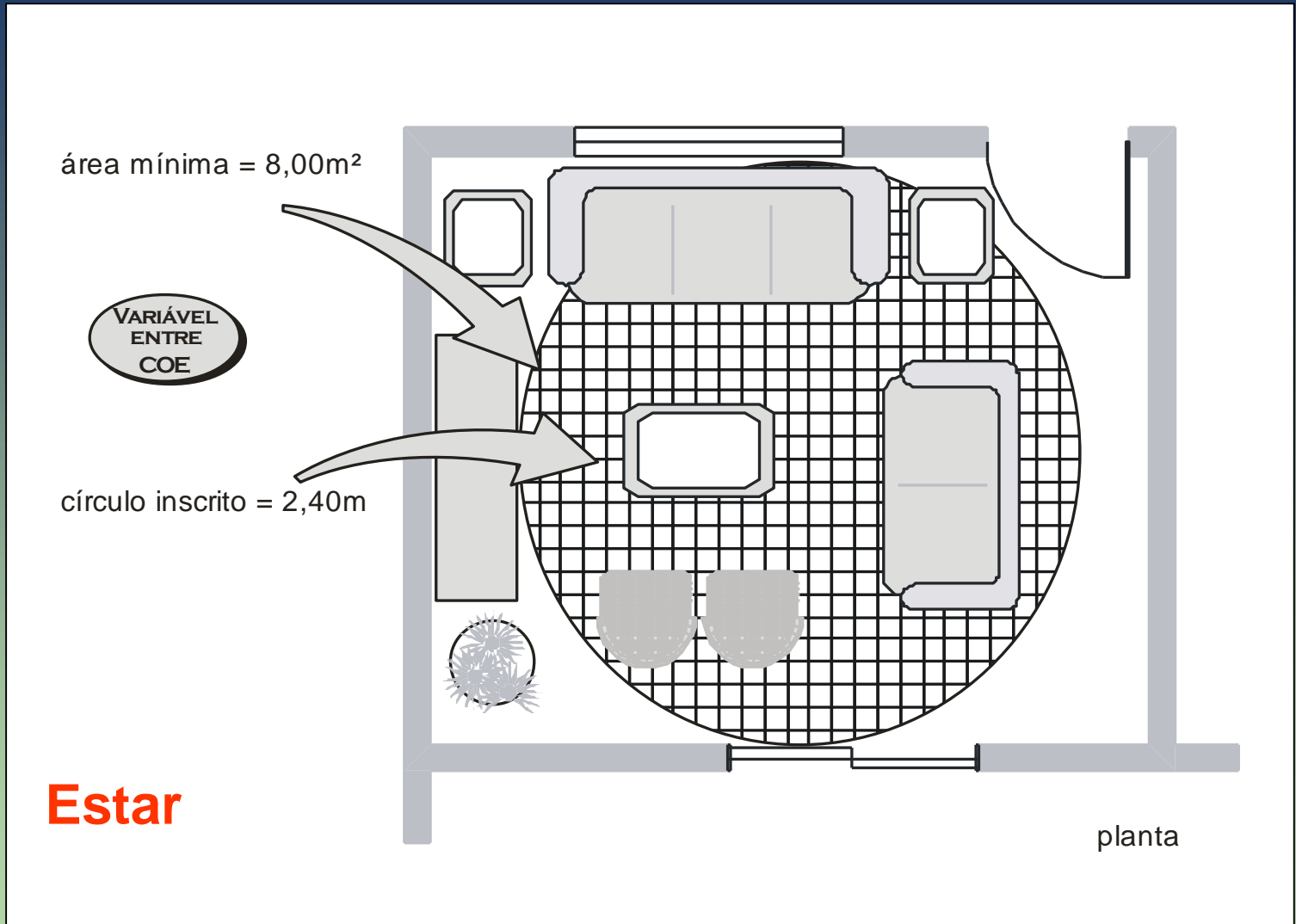

Legislação - habitação unifamiliar

profundidade máxima = 3 x o pé-direito

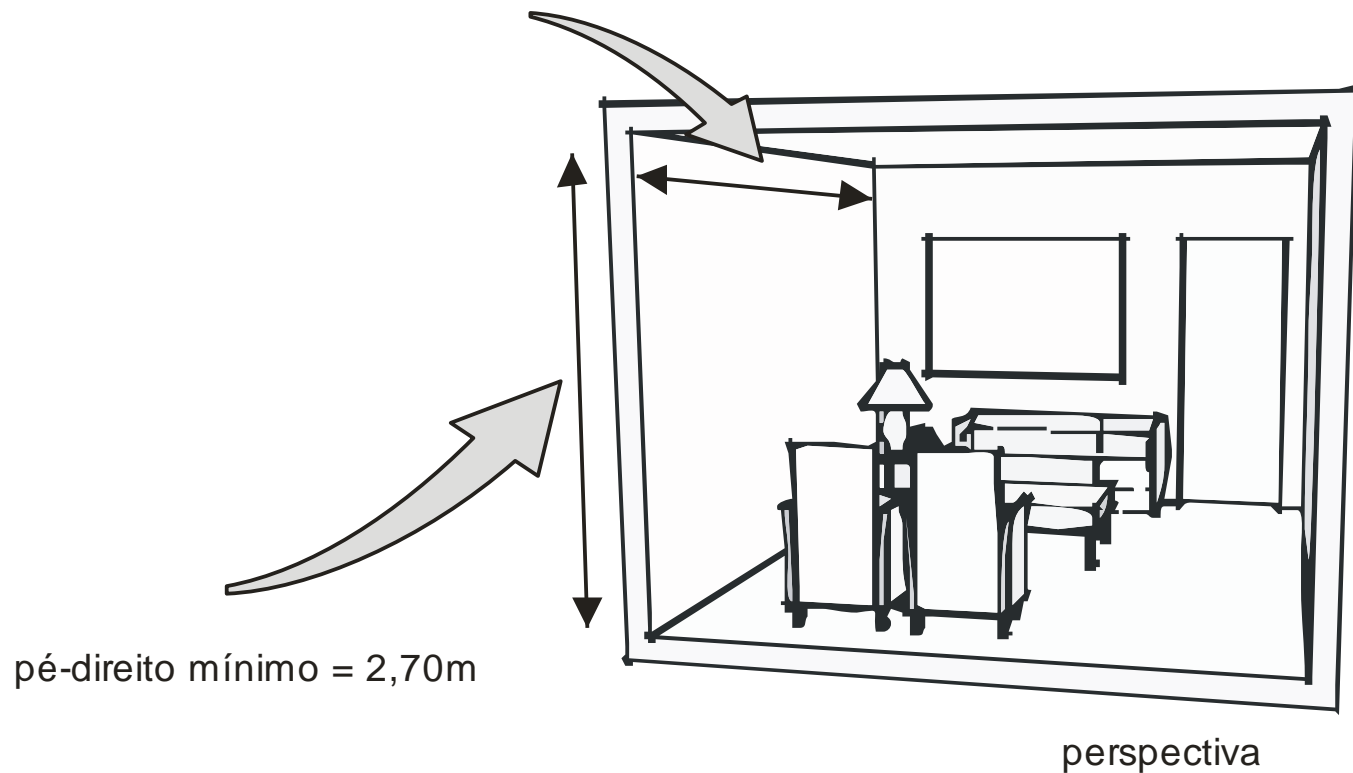

Legislação - habitação unifamiliar

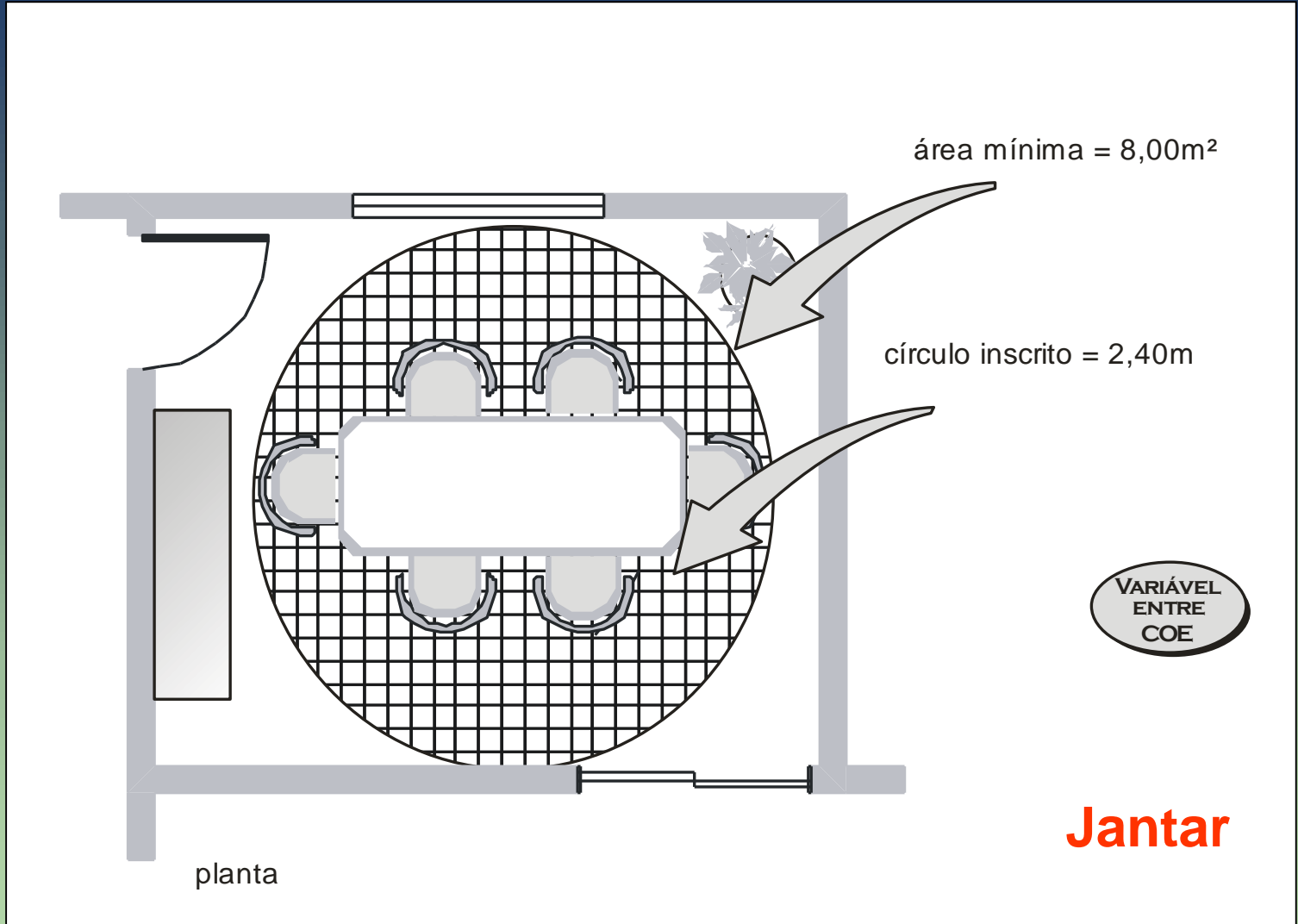

Legislação - habitação unifamiliar

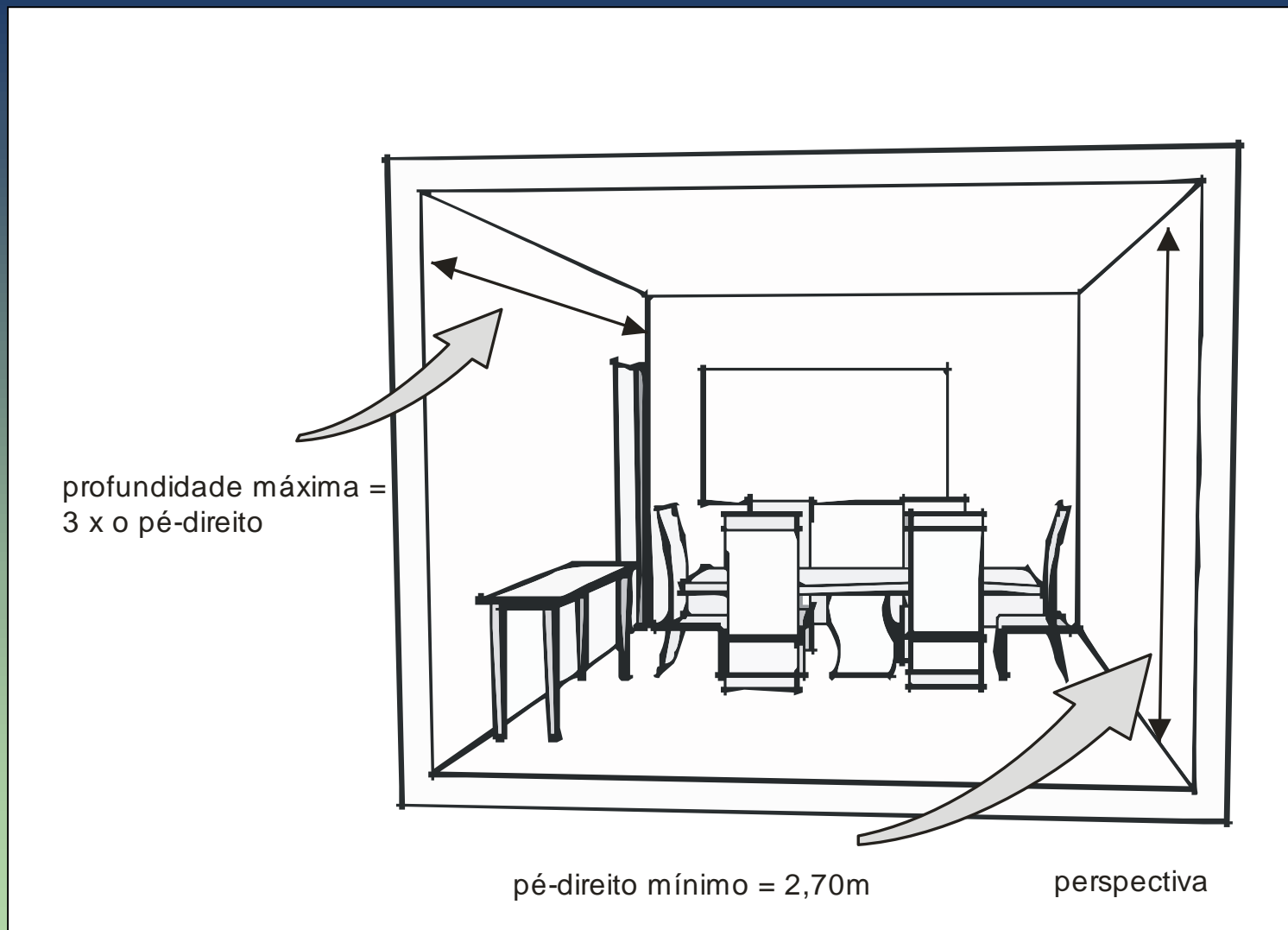

Legislação - habitação unifamiliar

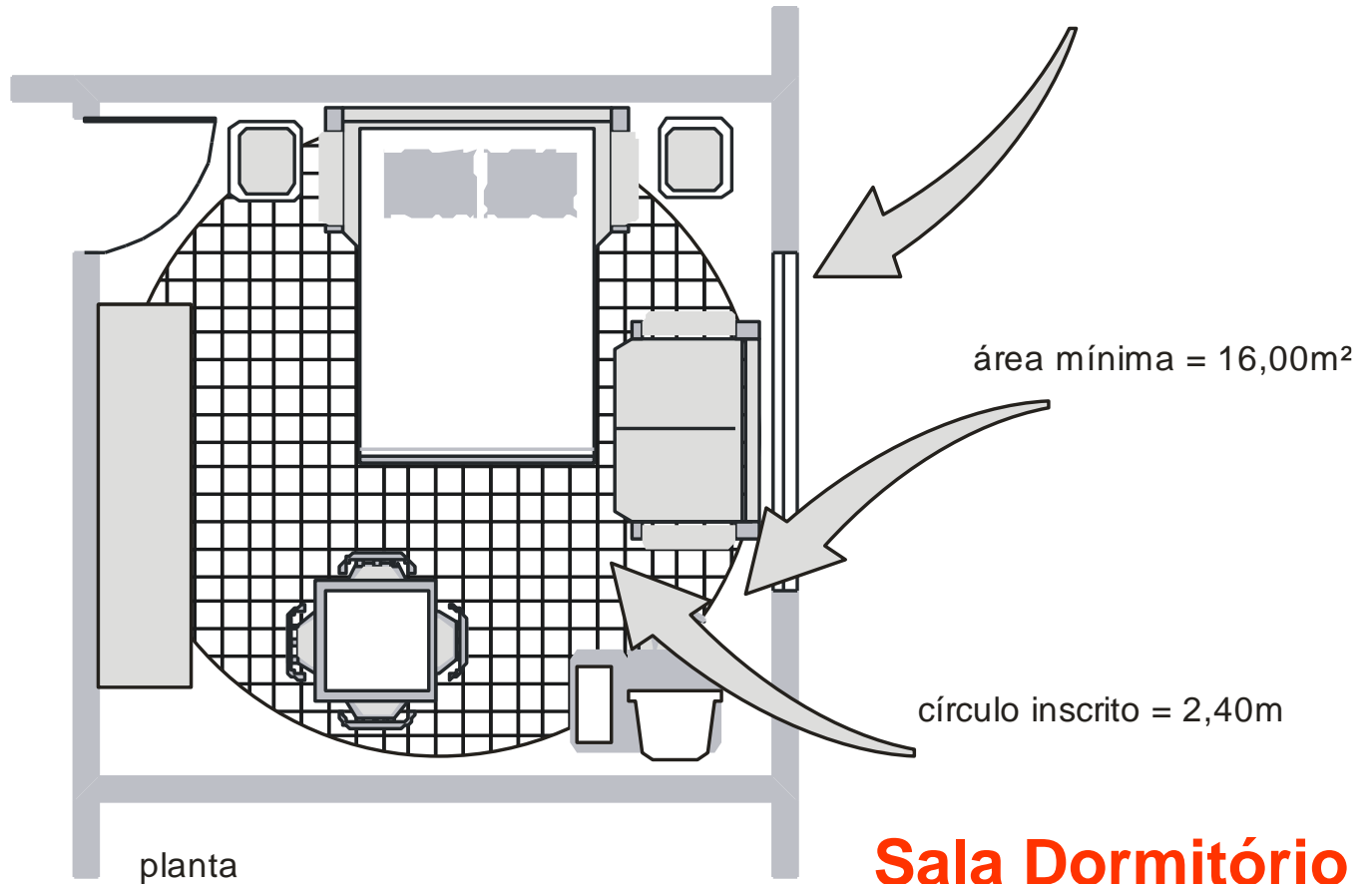

Legislação - habitação unifamiliar

VARIÁVEL
ENTRE
COE

profundidade máxima =
3 x o pé-direito

pé-direito mínimo = 2,70m

perspectiva

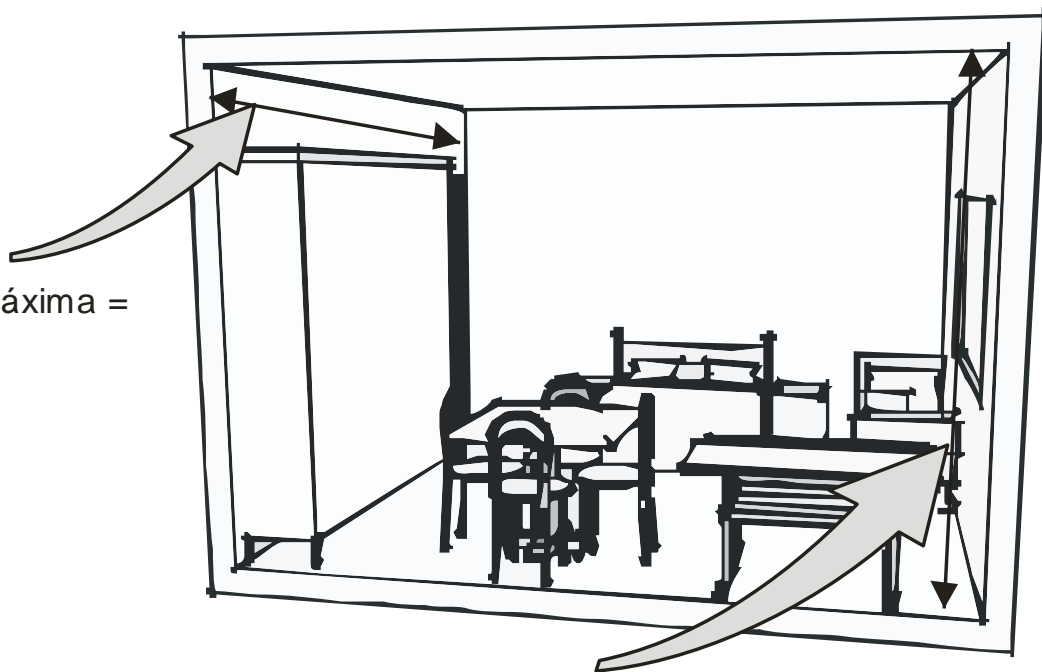

Legislação - habitação unifamiliar

Dormitório único

círculo inscrito = 2,40m

VARIÁVEL
ENTRE
COE

área mínima = 12,00m²

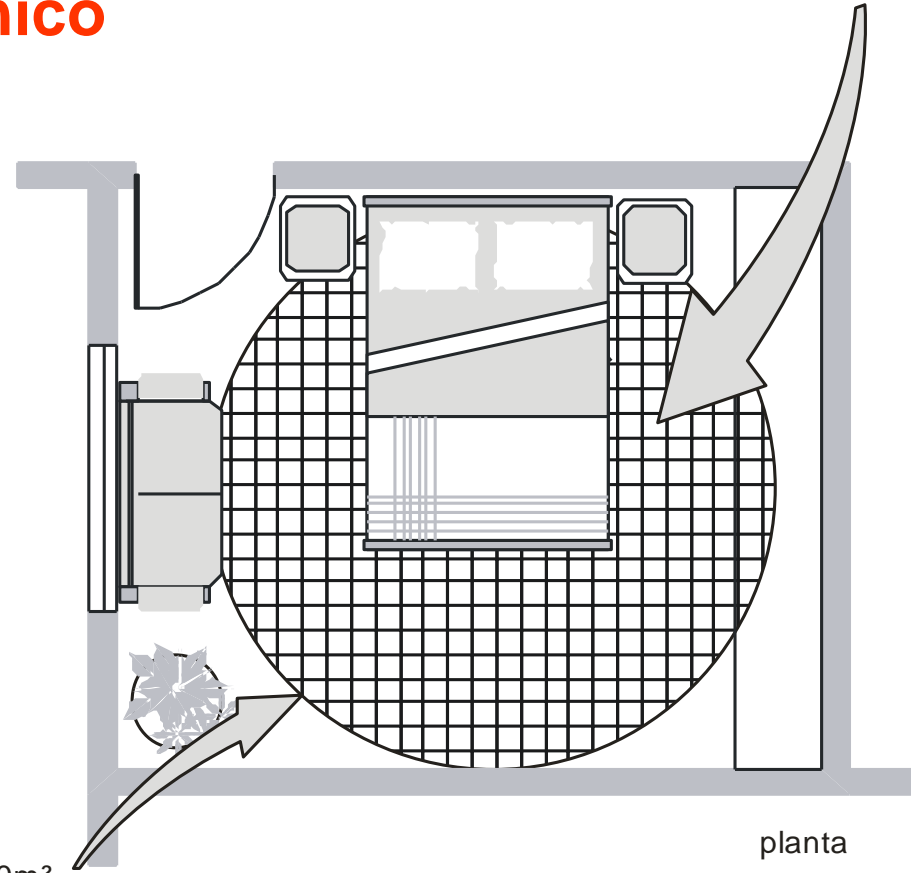

Legislação - habitação unifamiliar

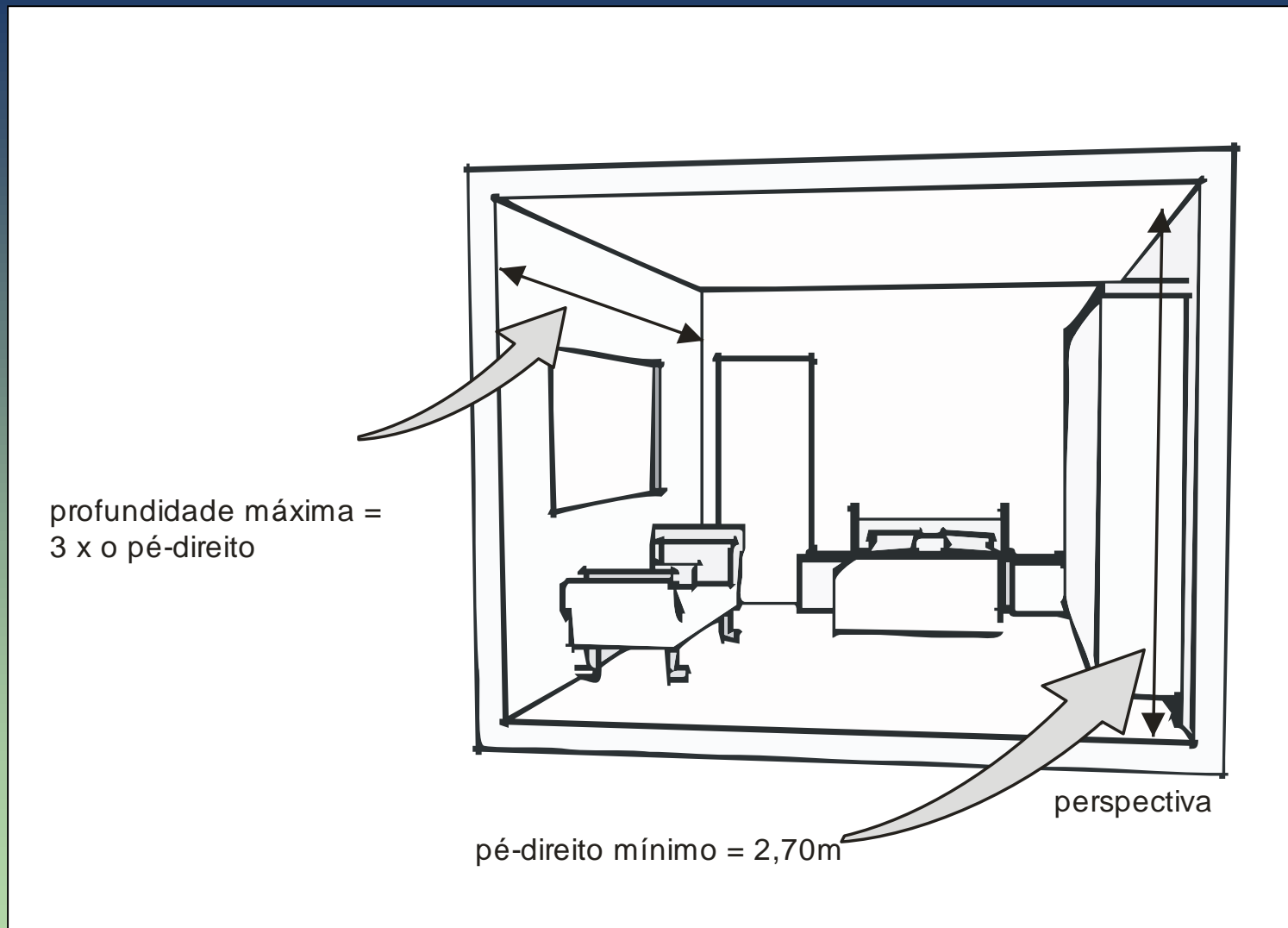

Legislação - habitação unifamiliar

2 Dormitórios

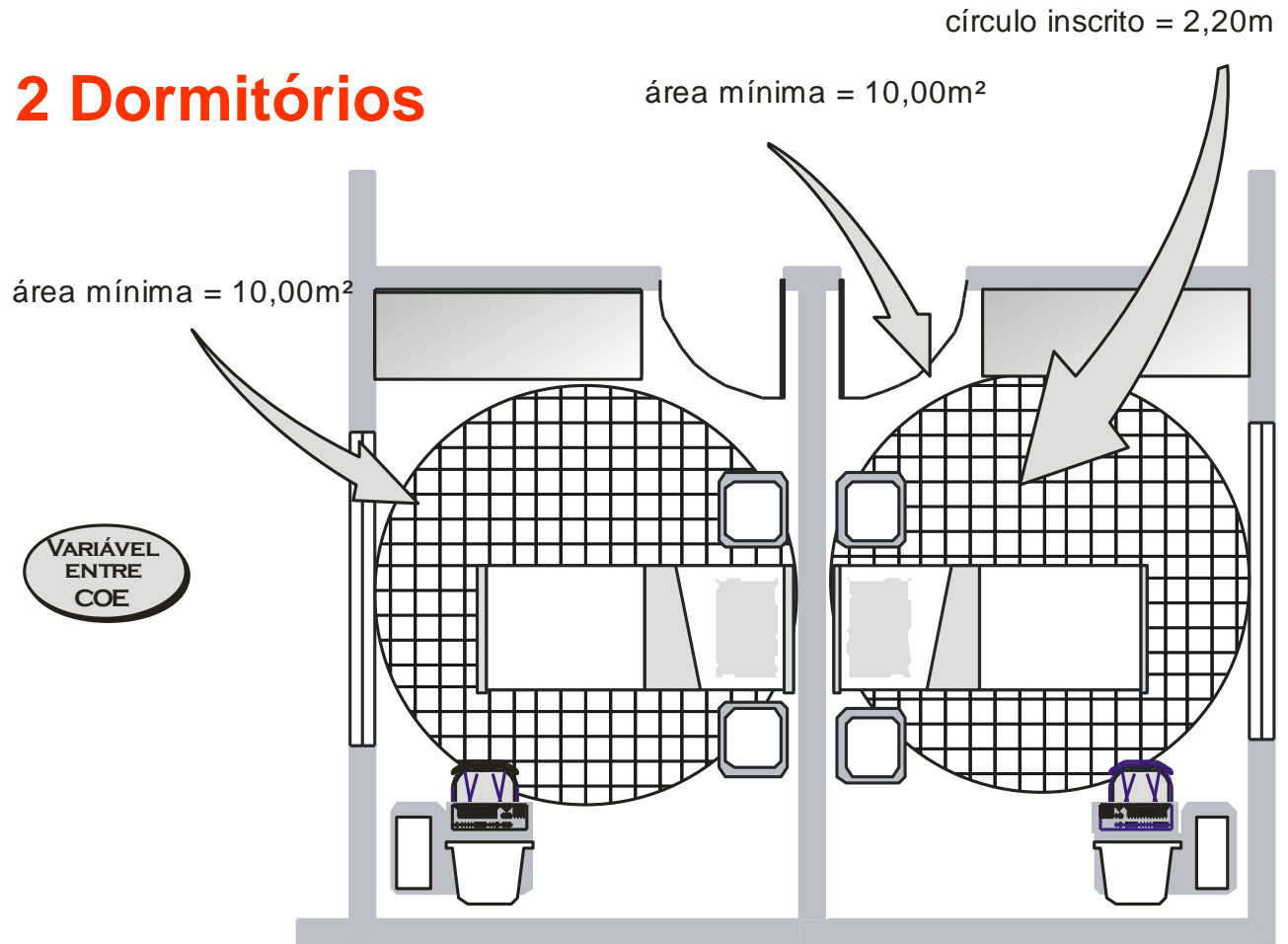

Legislação - habitação unifamiliar

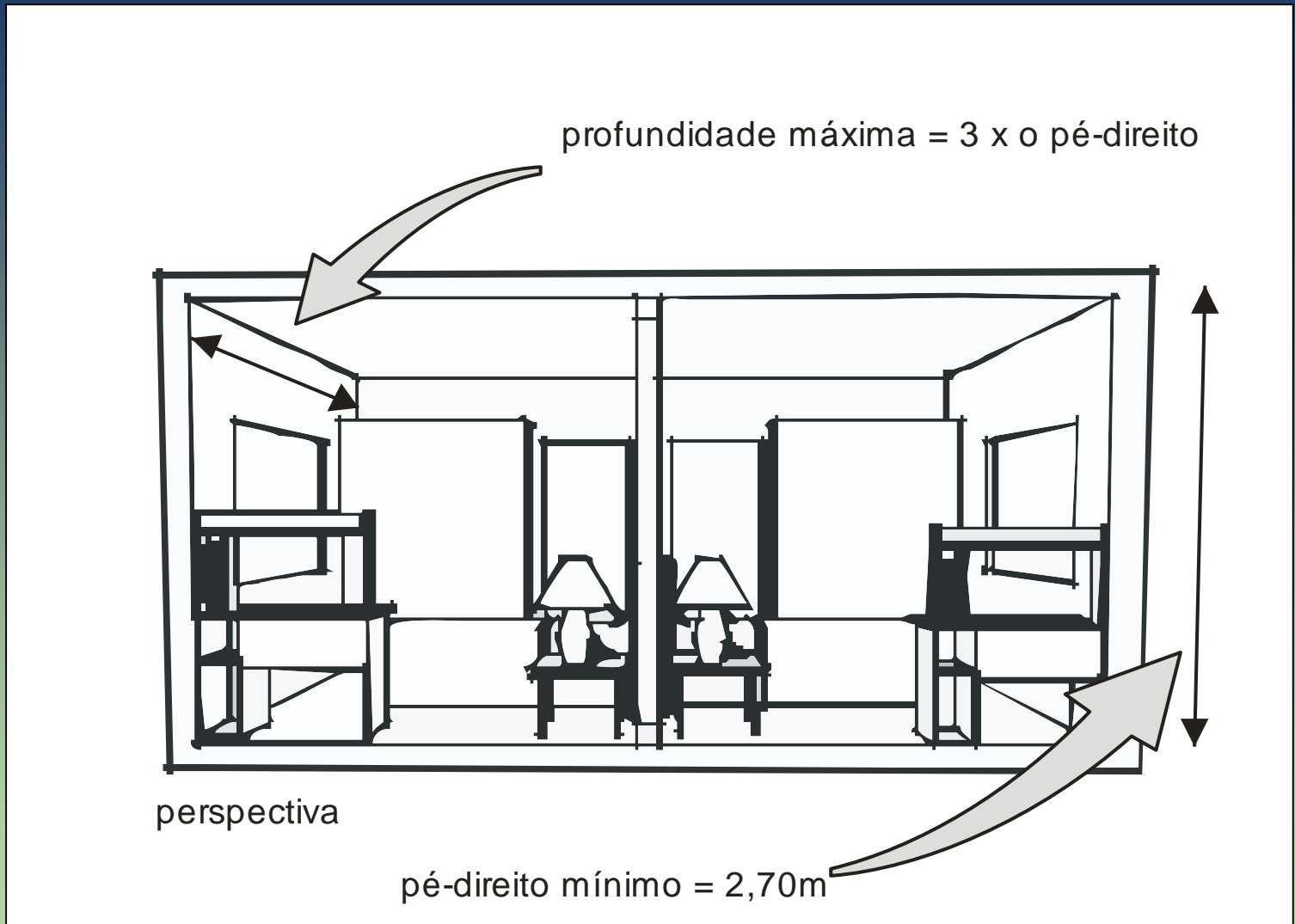

Legislação - habitação unifamiliar

3 Dormitórios

VARIÁVEL
ENTRE
COE

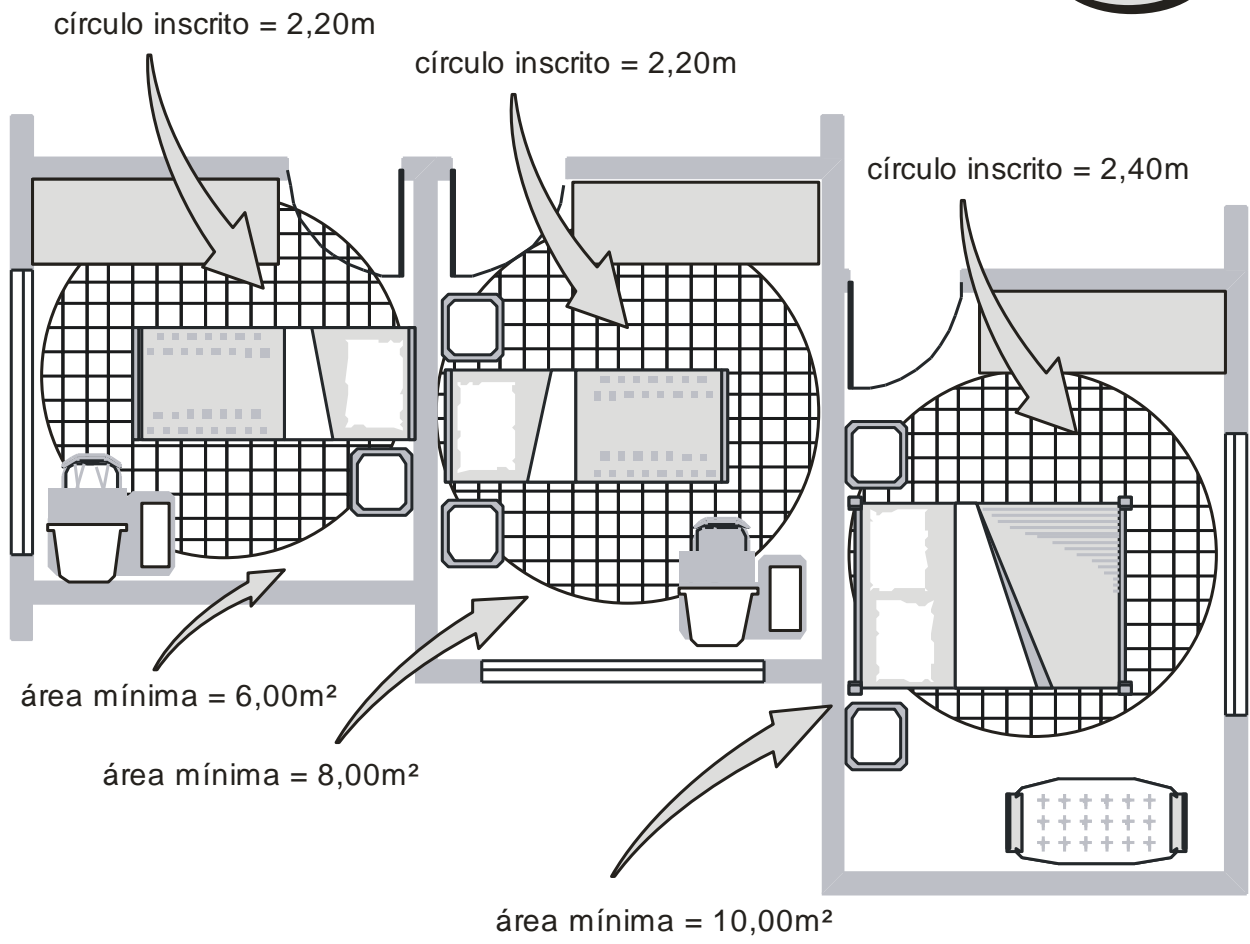

Legislação - habitação unifamiliar

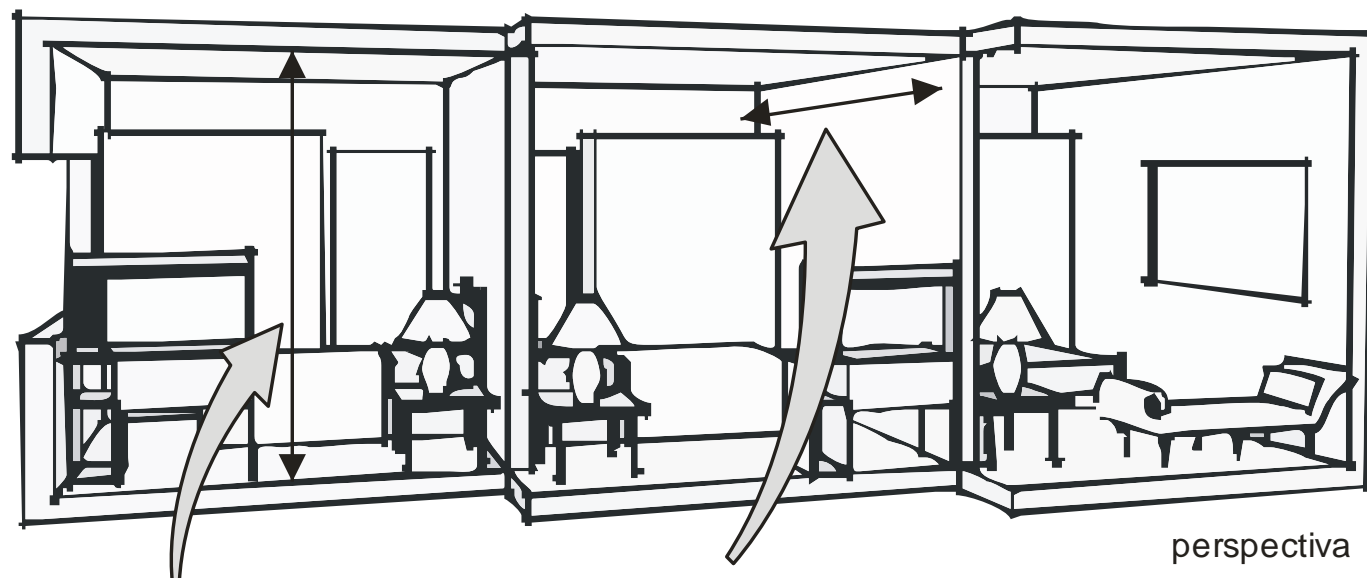

pé-direito mínimo = 2,70m

profundidade máxima = 3 x o pé-direito



Legislação - habitação unifamiliar

Copa

círculo inscrito = 1,50m

área mínima = 4,00m²

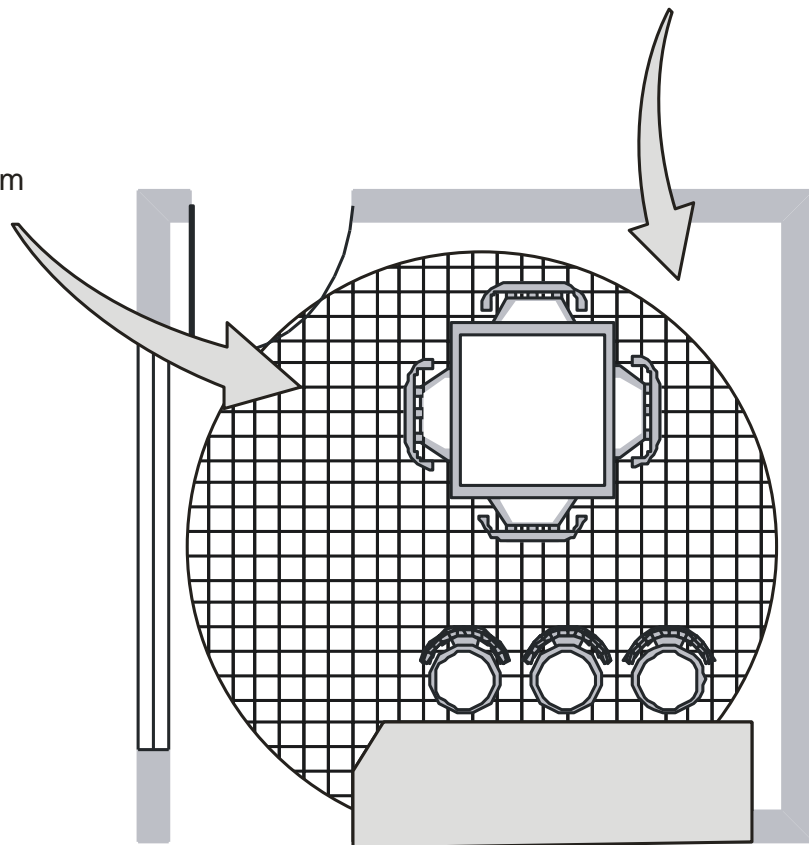

planta



Legislação - habitação unifamiliar

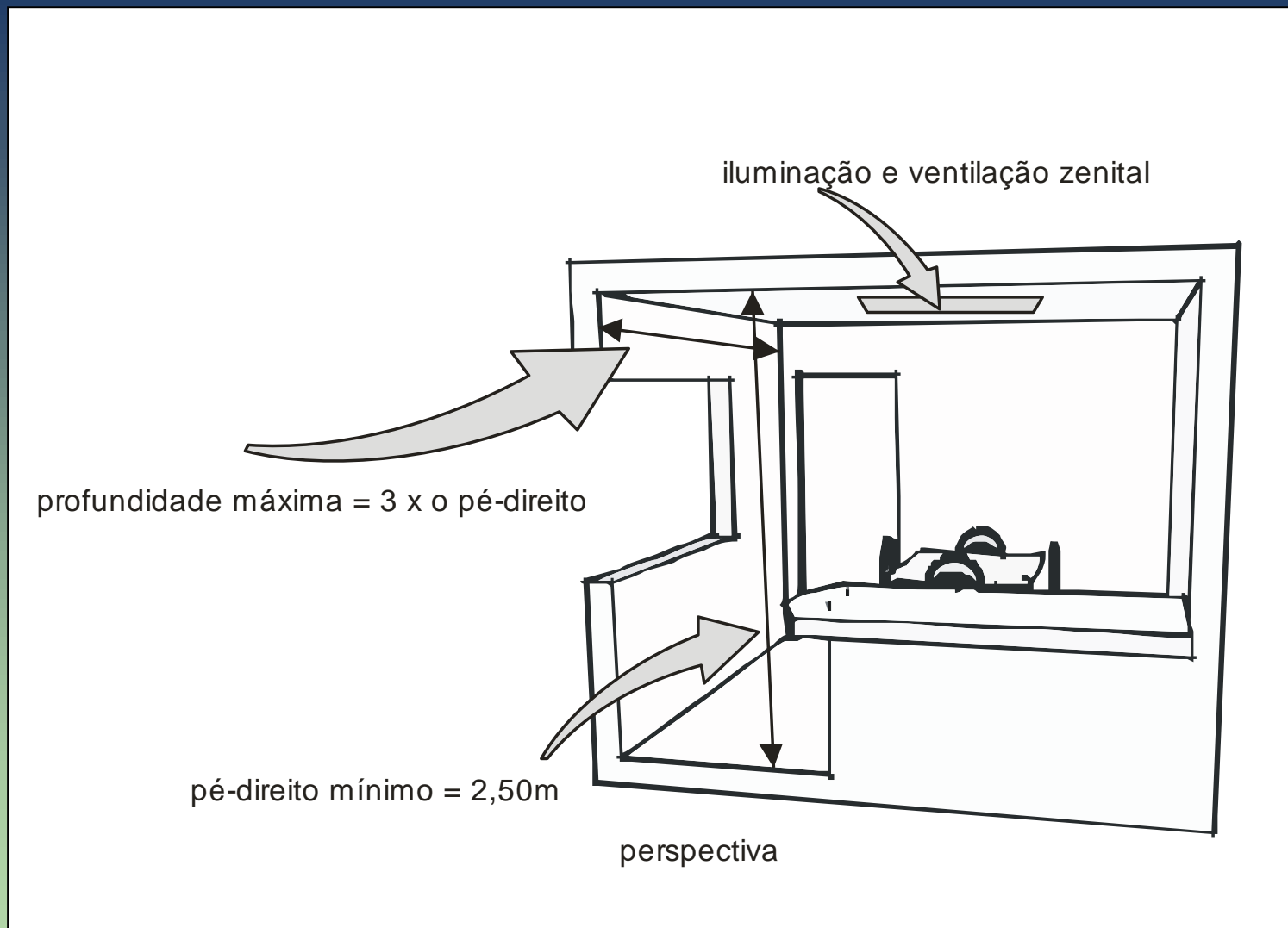

Legislação - habitação unifamiliar

Cozinha

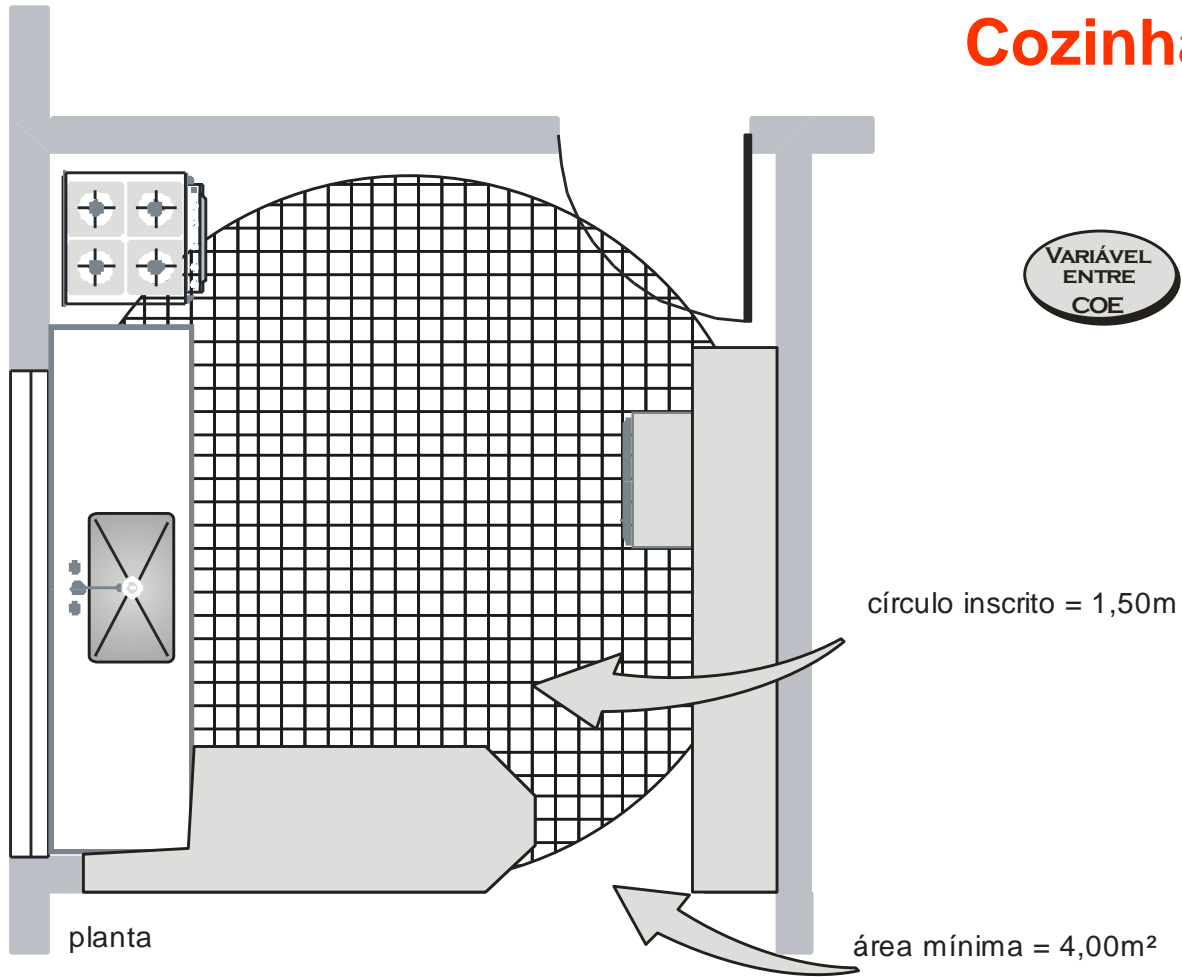

Legislação - habitação unifamiliar

pé-direito mínimo = 2,50m

profundidade máxima =
3 x o pé-direito

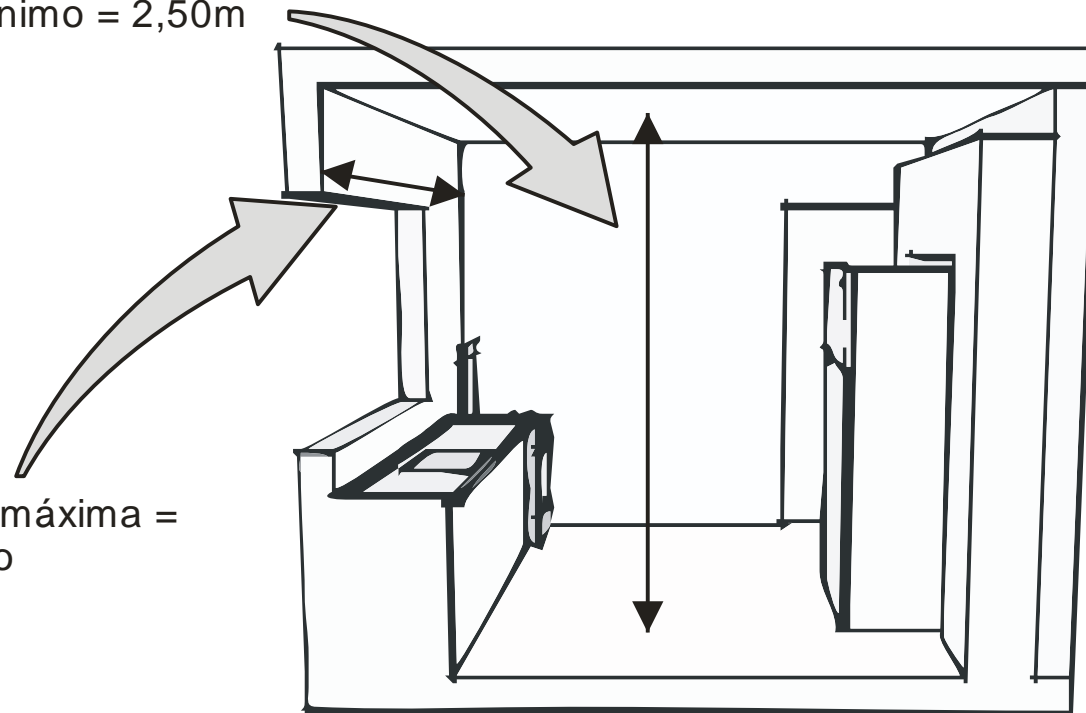

perspectiva



Legislação - habitação unifamiliar

lavanderia

VARIÁVEL
ENTRE
COE

círculo inscrito = 1,20m

área mínima = 2,50m²

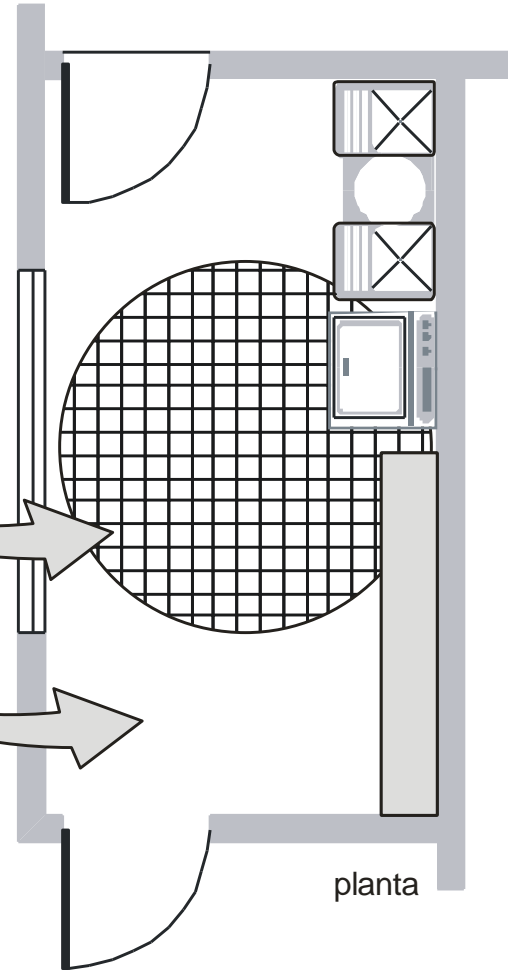

Legislação - habitação unifamiliar

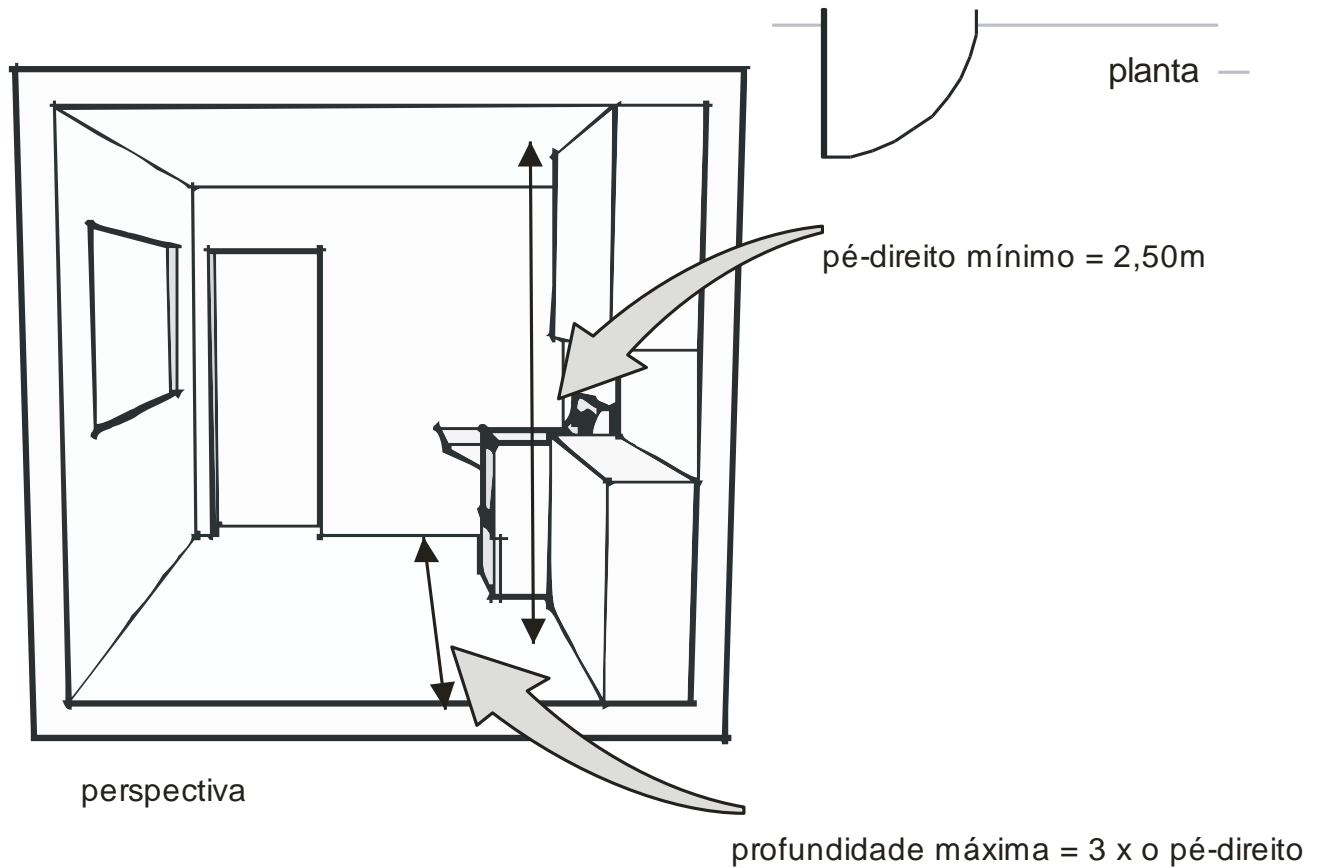

Legislação - habitação unifamiliar

Banheiro

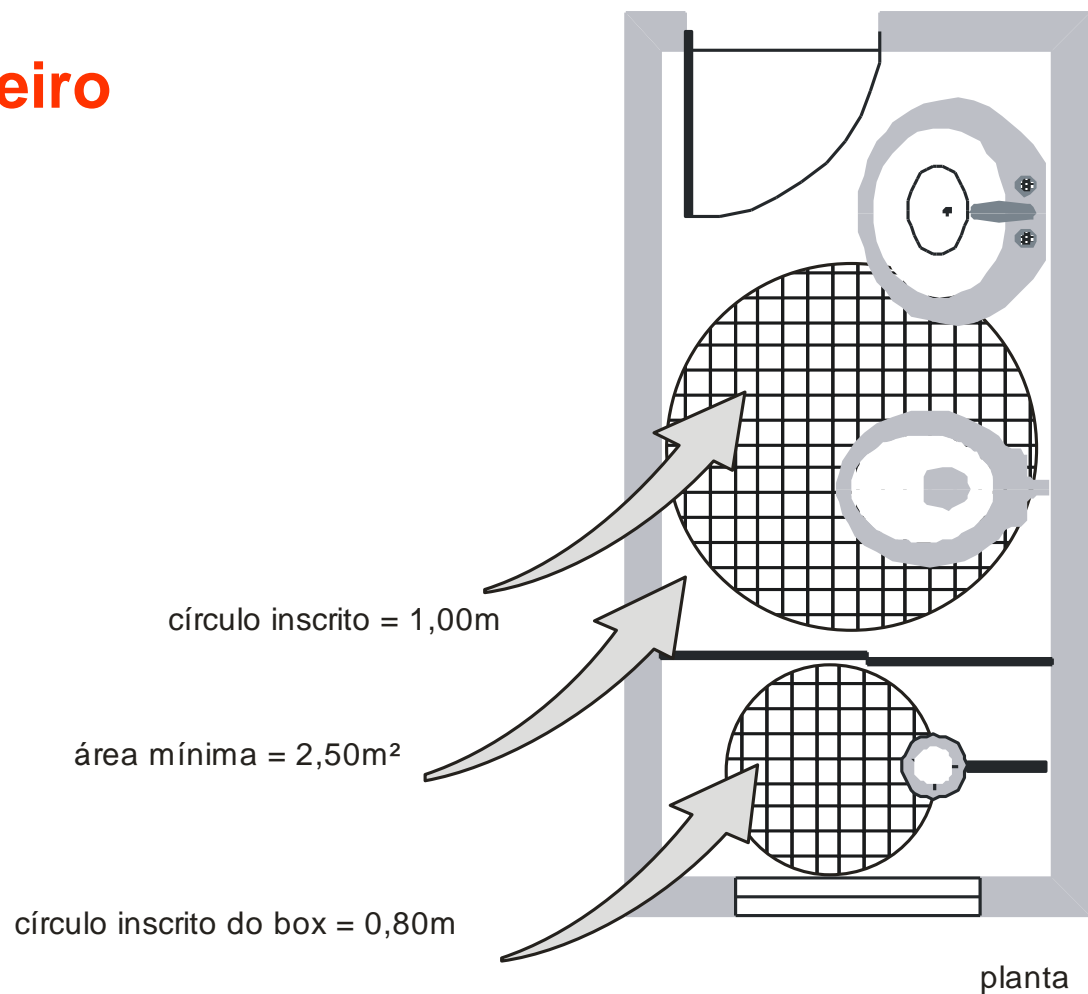

Legislação - habitação unifamiliar

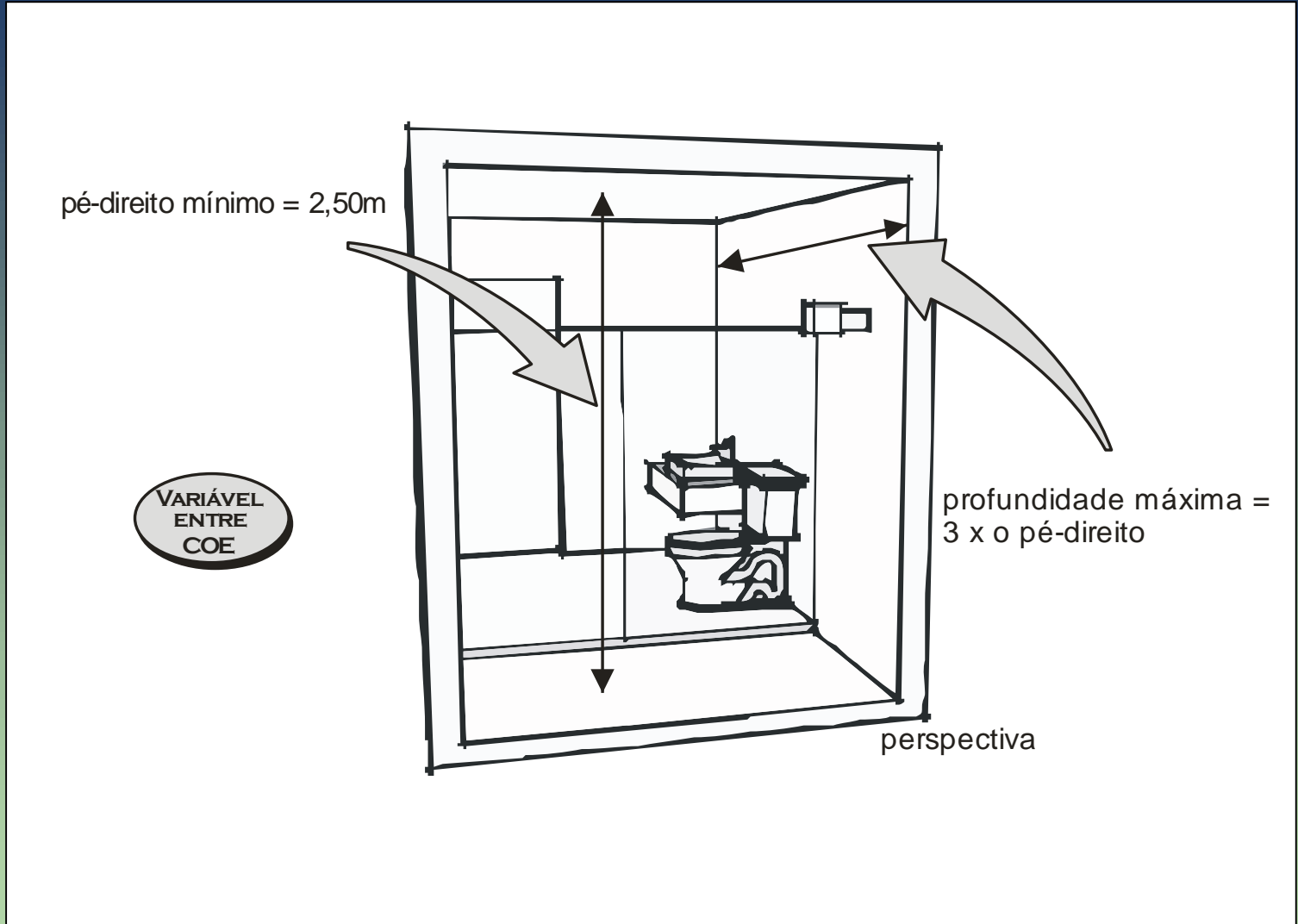

Legislação - habitação unifamiliar

Vestir

círculo inscrito = 1,20m

área mínima = 1,44m²

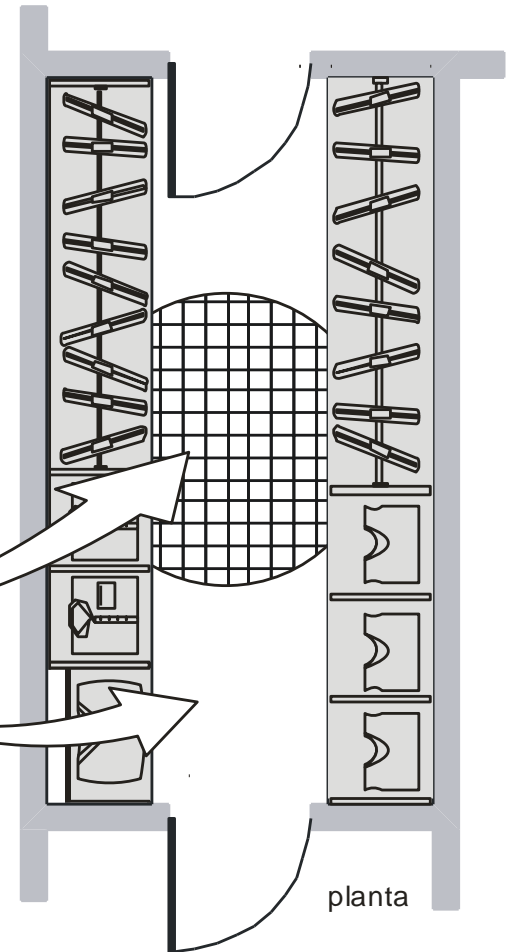

Legislação - habitação unifamiliar

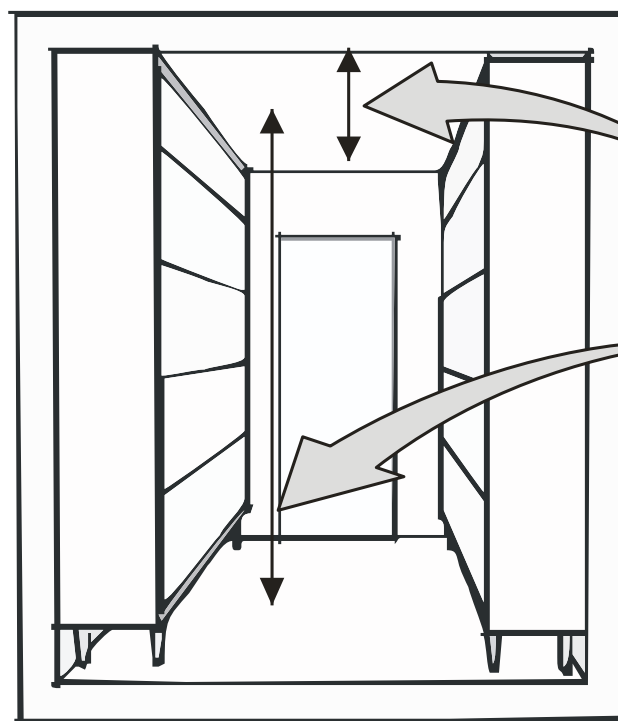

profundidade máxima = 3 x o pé-direito

pé-direito mínimo = 2,50m

VARIÁVEL
ENTRE
COE

perspectiva



Legislação - habitação unifamiliar

Garagem

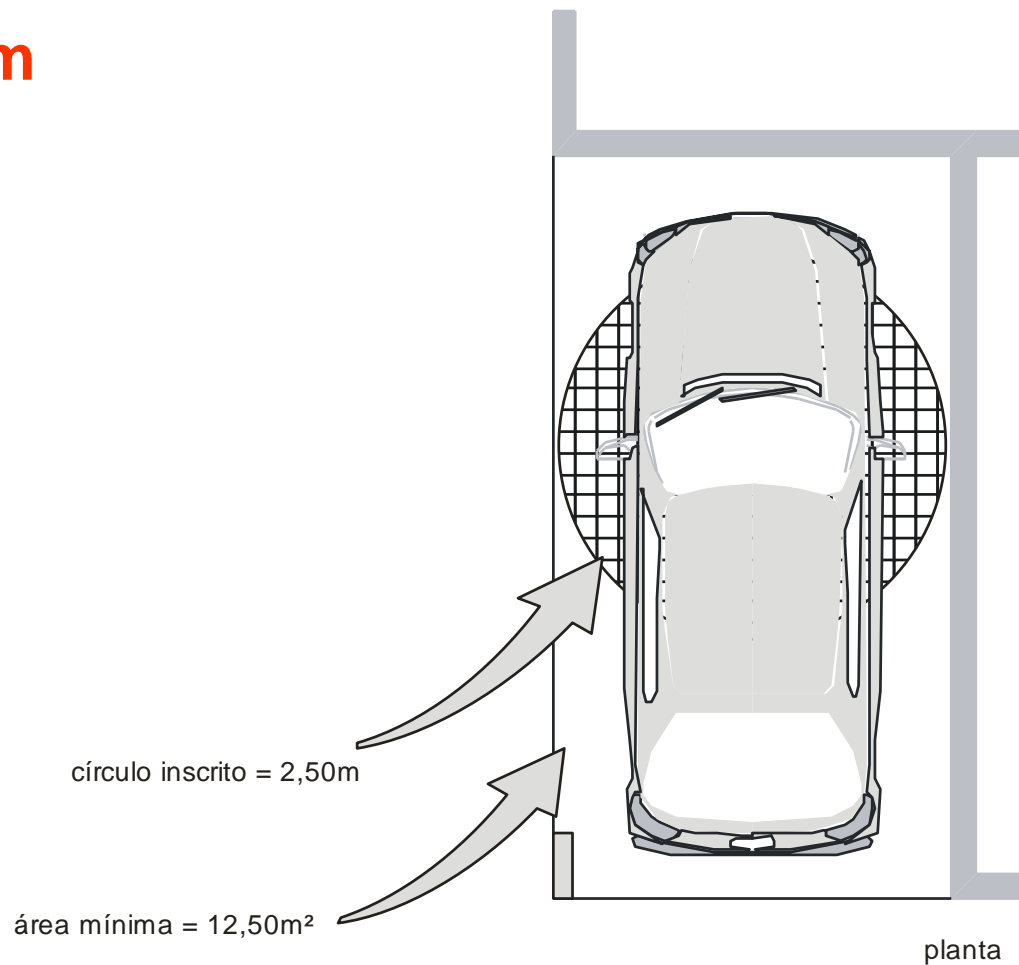

Legislação - habitação unifamiliar

área mínima = 12,50m²

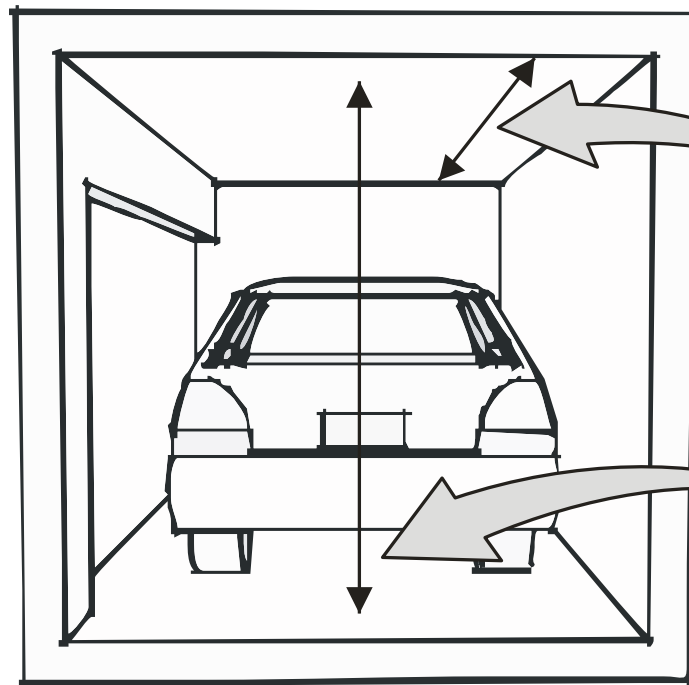

VARIÁVEL
ENTRE
COE

profundidade máxima = 3 x o pé-direito

pé-direito mínimo = 2,30m



Legislação - habitação unifamiliar

Dormir Serv.

VARIÁVEL
ENTRE
COE

círculo inscrito = 1,60m

área mínima = 6,00m²

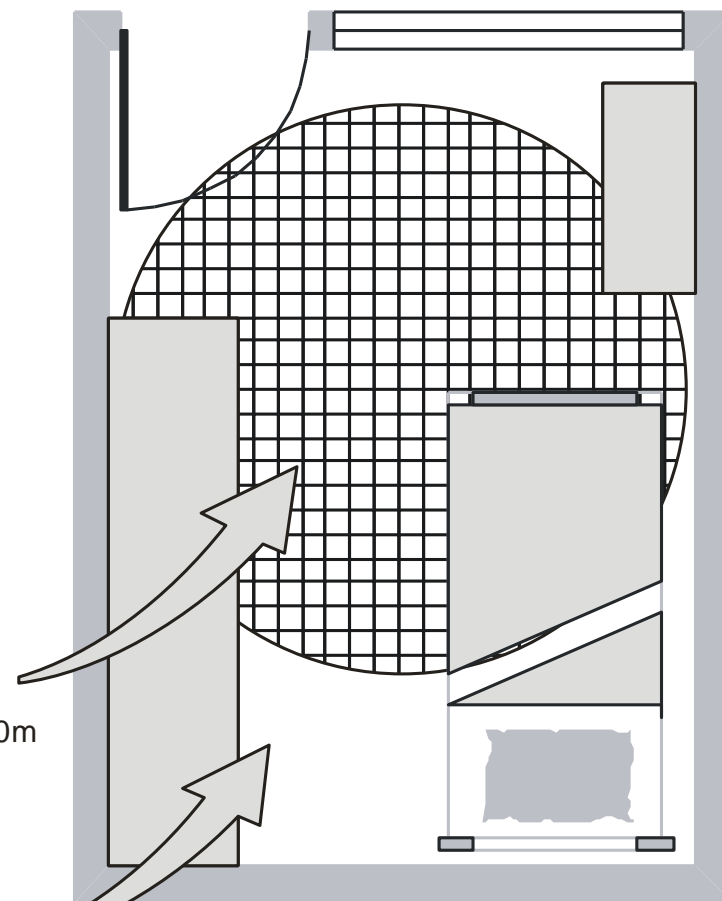

planta



Legislação - habitação unifamiliar

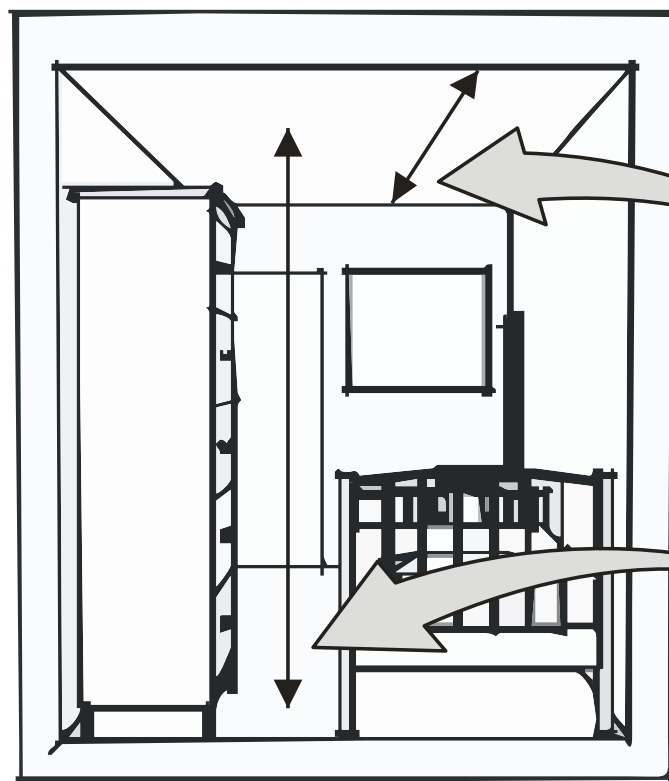

profundidade máxima = 3 x o pé-direito

pé-direito mínimo = 2,70m

perspectiva



Legislação - habitação unifamiliar

Circulação

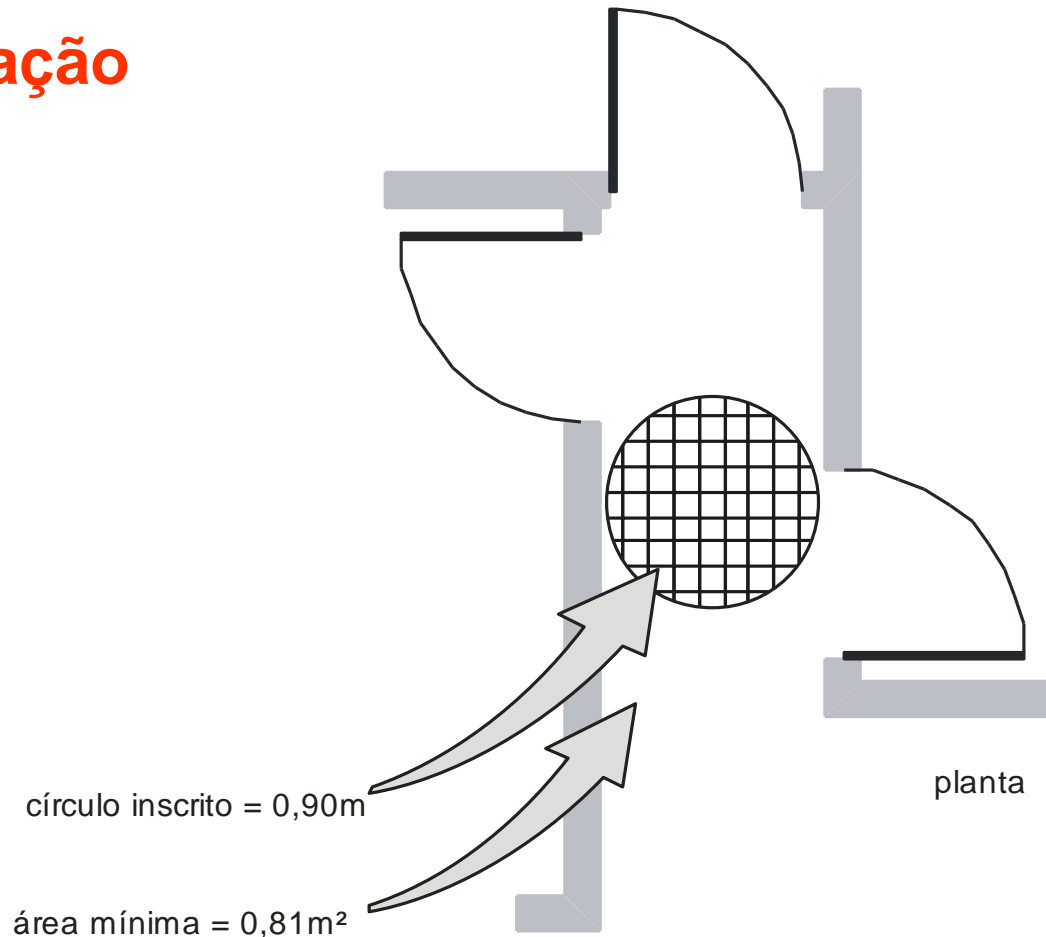

Legislação - habitação unifamiliar

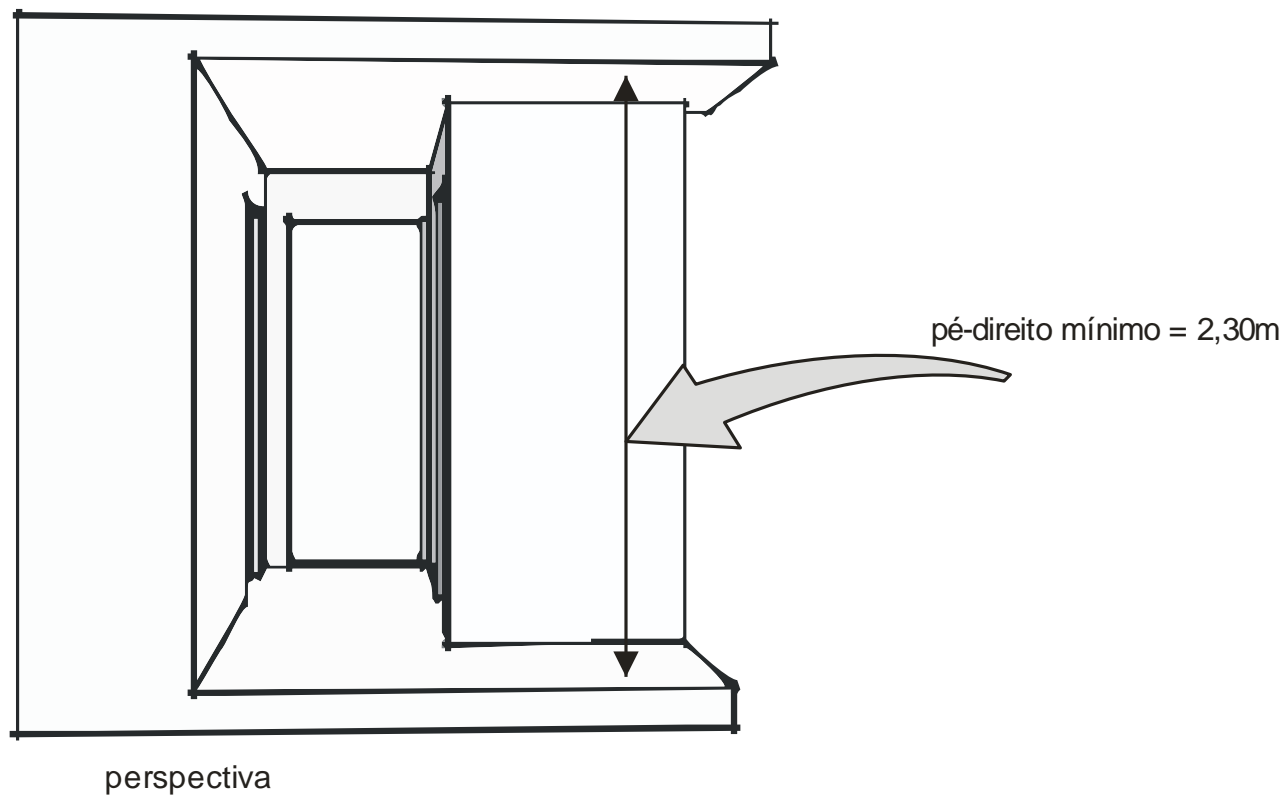

Legislação - habitação unifamiliar

Escritório

VARIÁVEL
ENTRE
COE

círculo inscrito = 2,40m

área mínima = 6,00m²

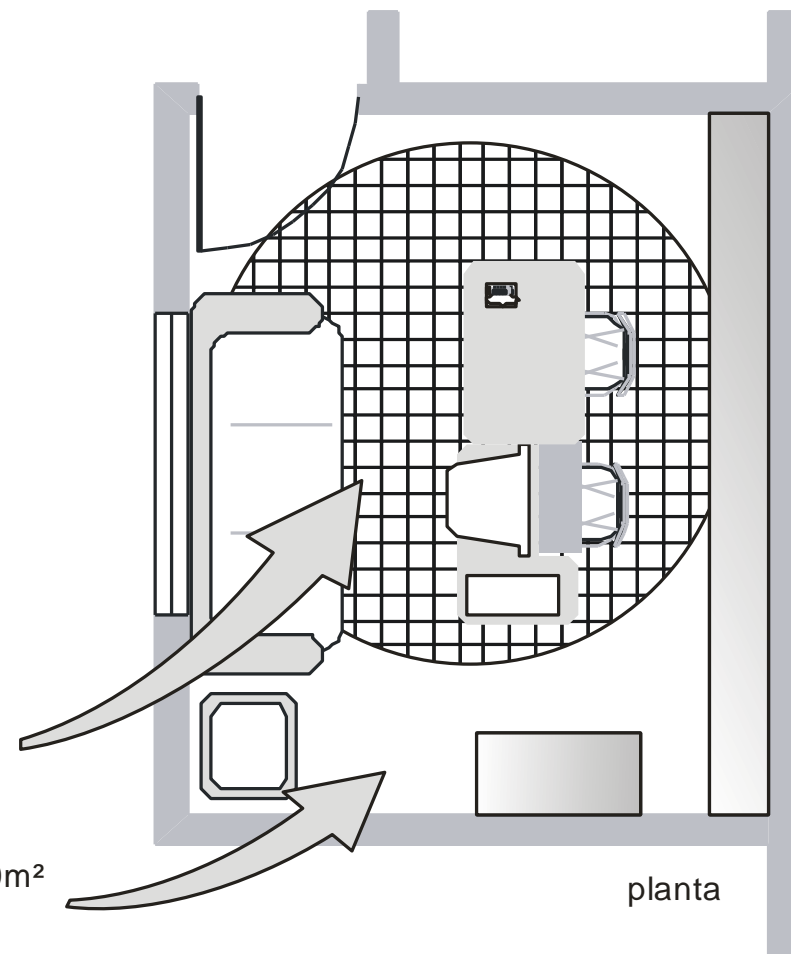

Legislação - habitação unifamiliar

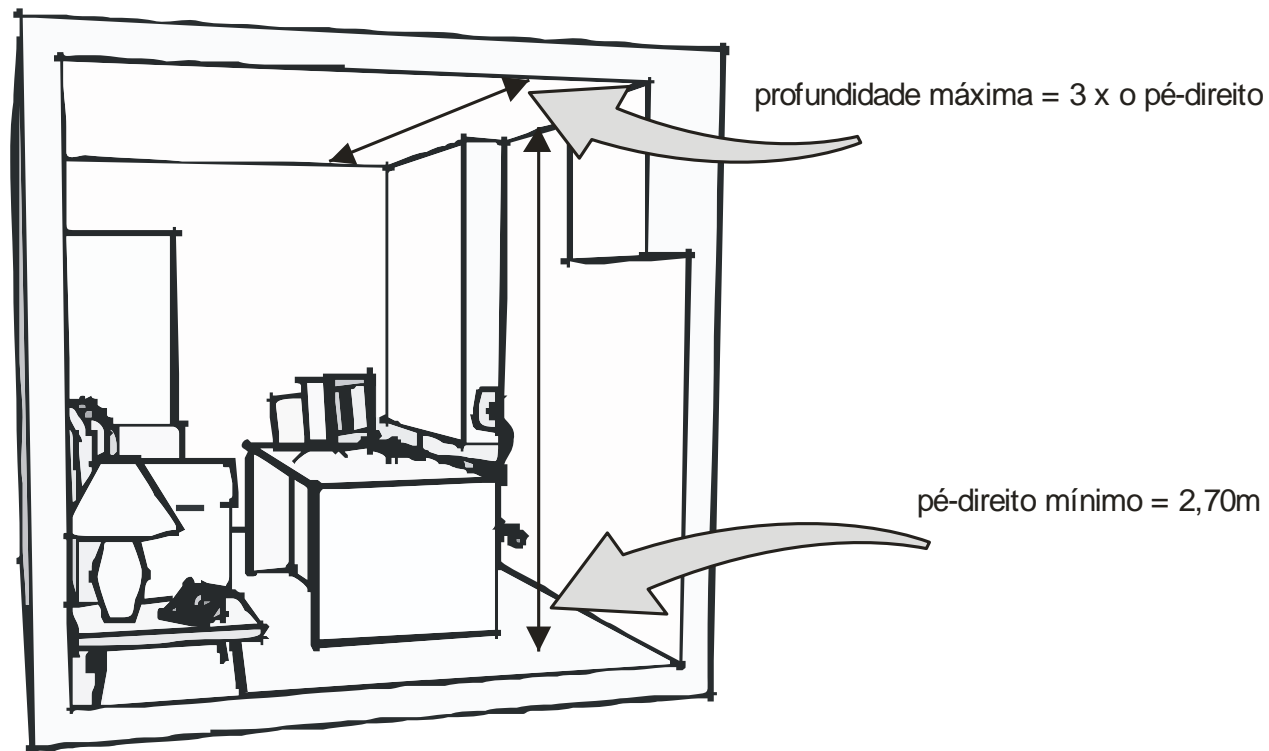

perspectiva



Legislação - habitação unifamiliar

Lavabo

círculo inscrito = 1,00m

área mínima = 1,50m²

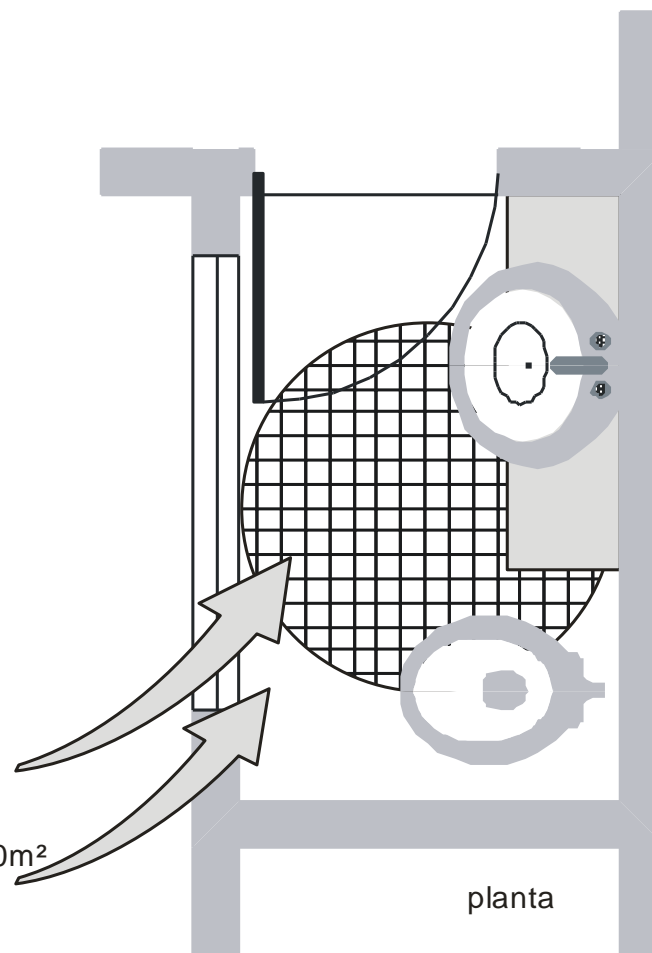

Legislação - habitação unifamiliar

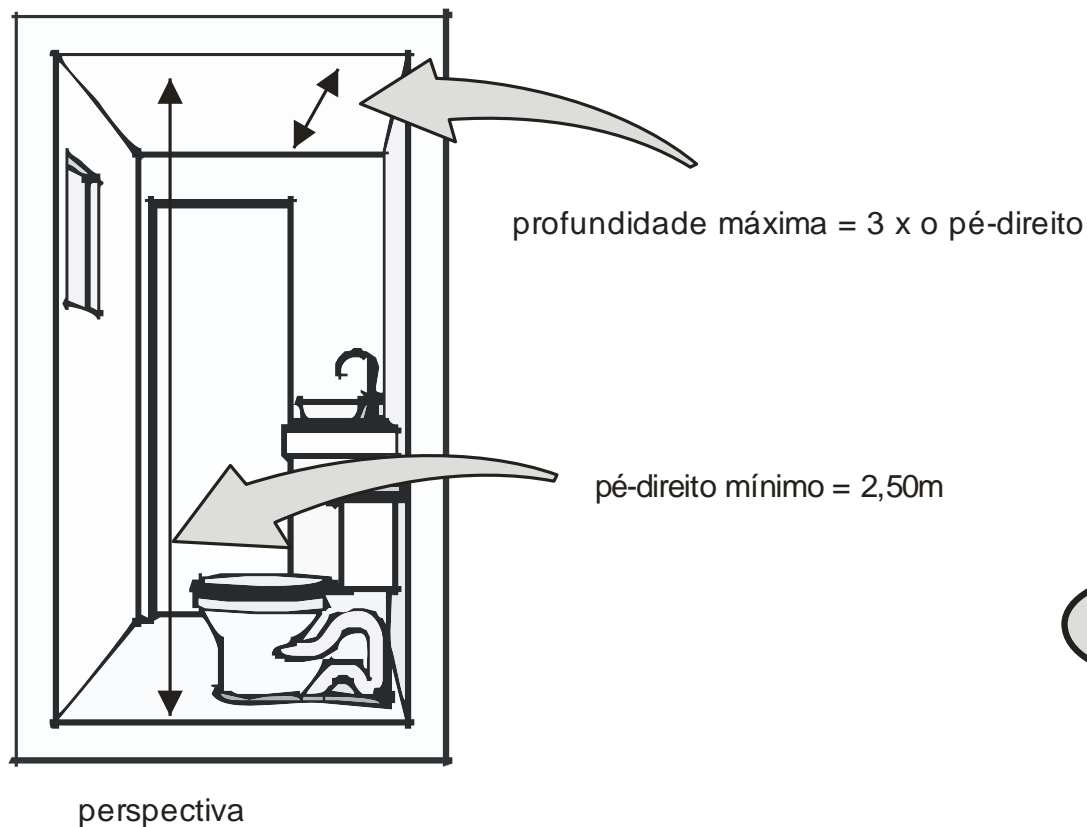

VARIÁVEL
ENTRE
COE



Legislação - habitação unifamiliar

Depósito

círculo inscrito = 1,20m

área mínima = 2,00m²

planta

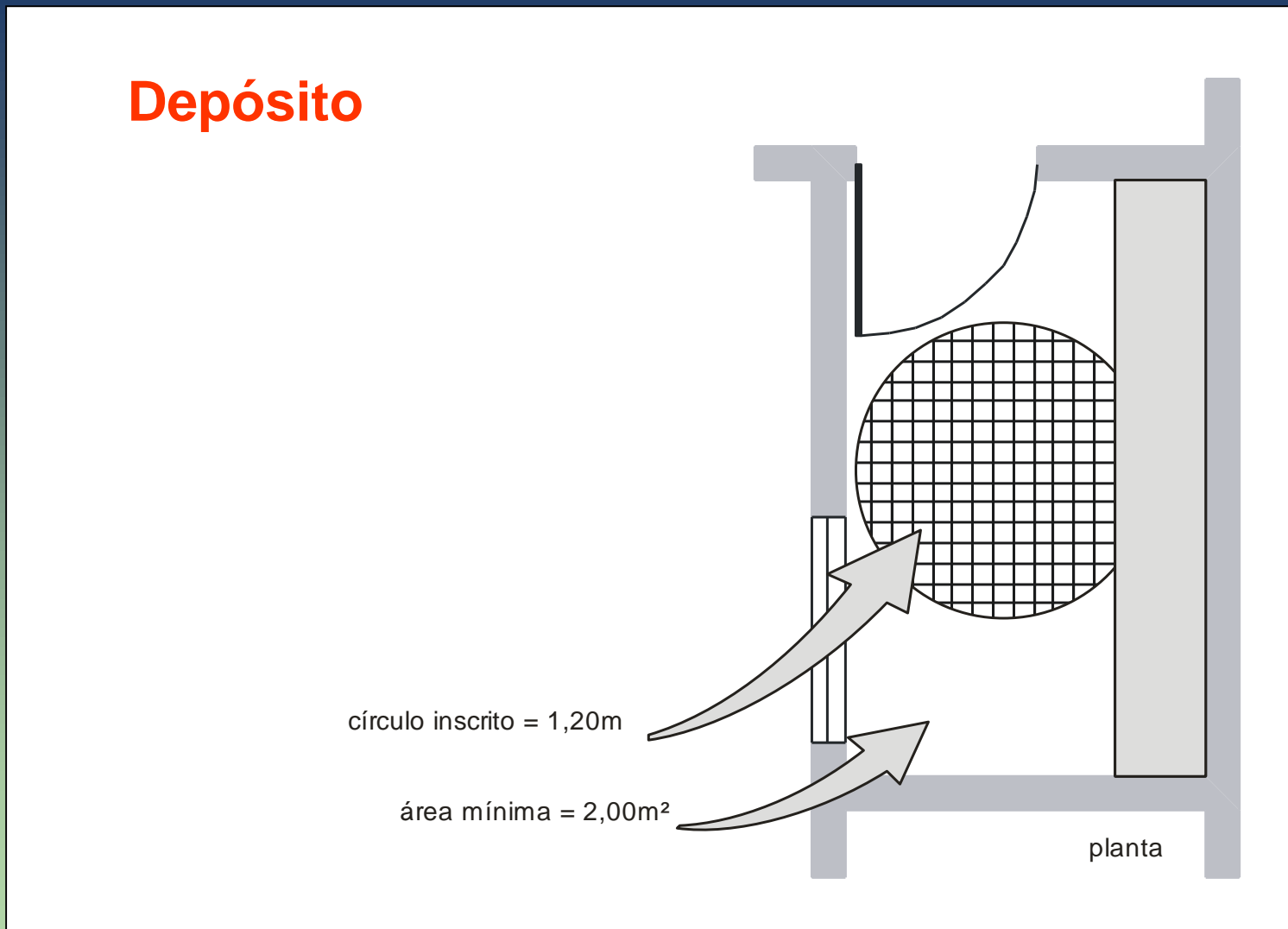

Legislação - habitação unifamiliar

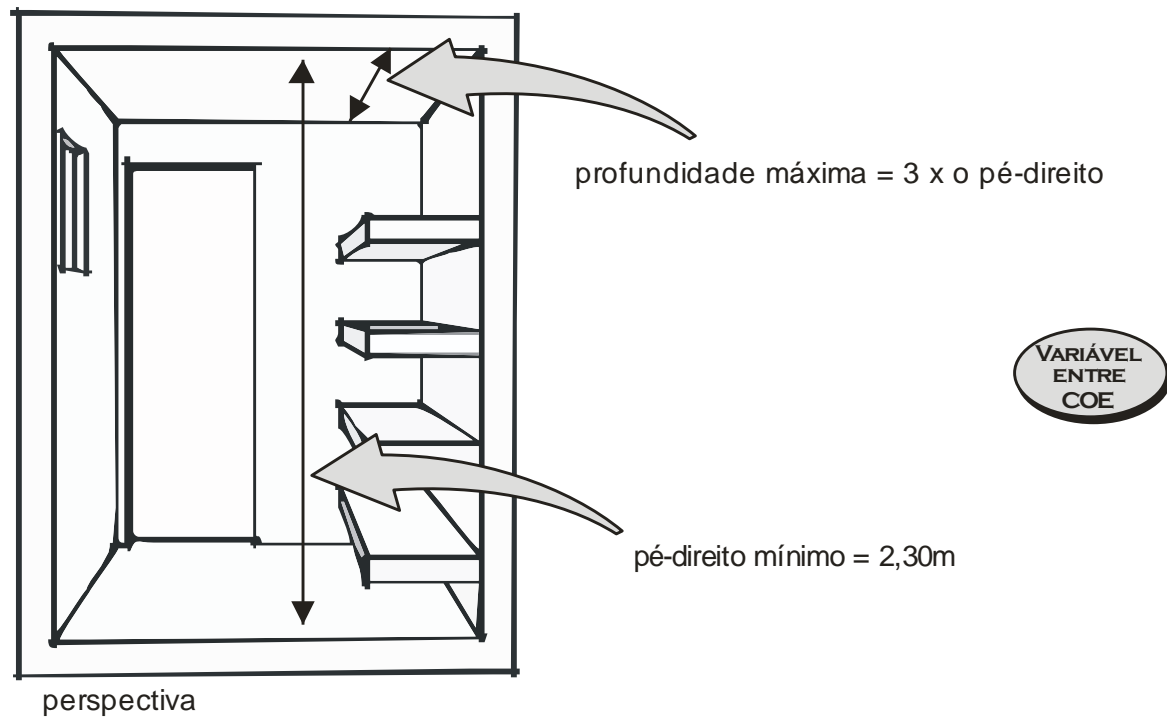

Legislação - habitação unifamiliar

Vestíbulo

círculo inscrito = 0,90m

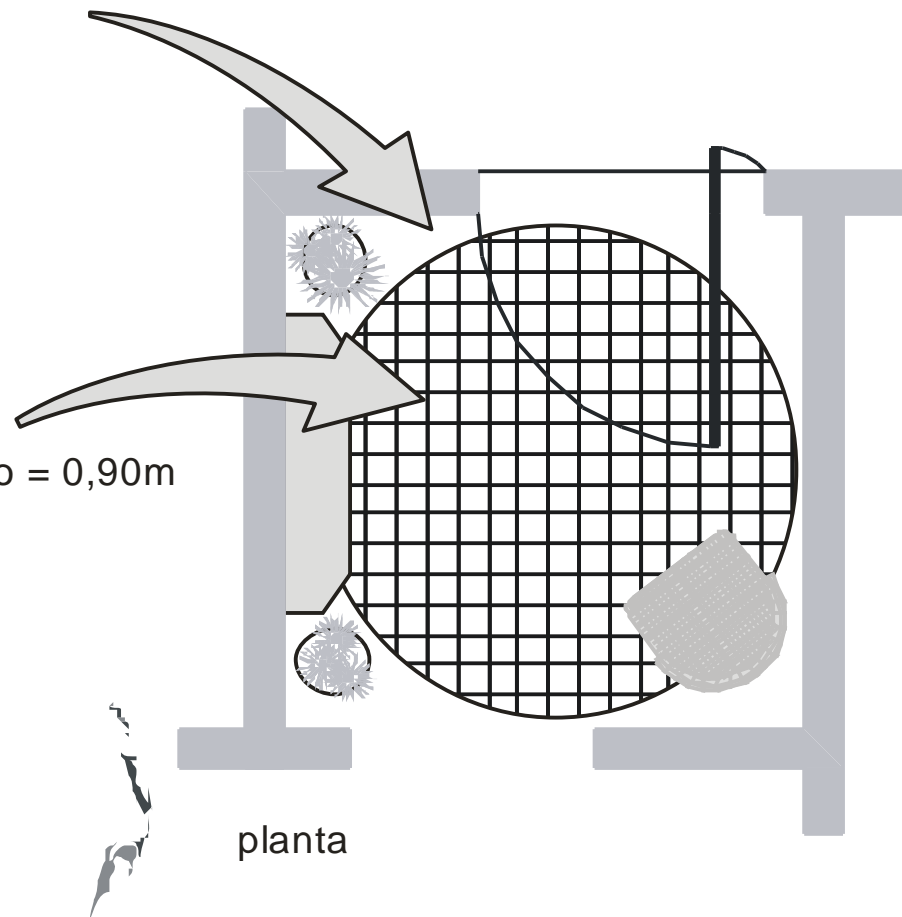

Legislação - habitação unifamiliar

VARIÁVEL
ENTRE
COE

pé-direito mínimo = 2,30m

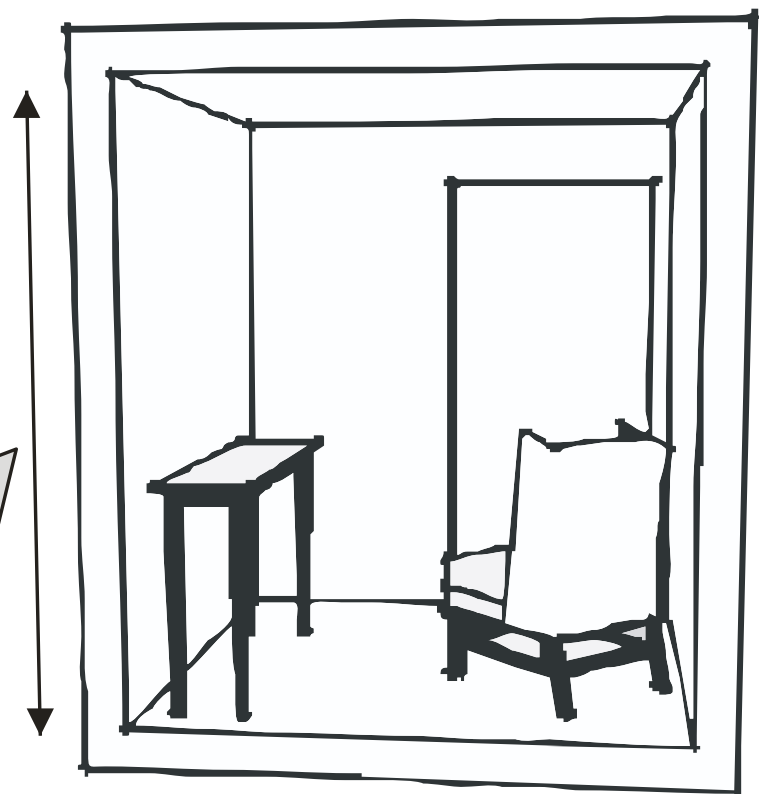

perspectiva



Legislação - habitação unifamiliar

Escada

área mínima = não tem

círculo inscrito = 0,90m

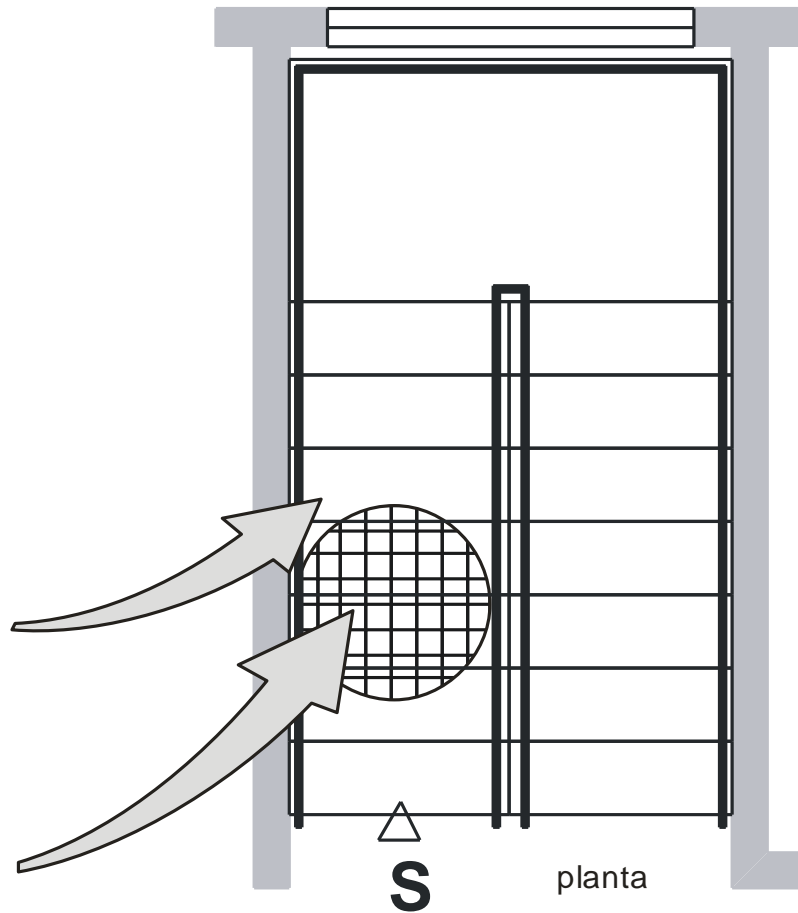

Legislação - habitação unifamiliar

